

RICOH COLOR LASER AP505

OPERATING INSTRUCTIONS Printer Reference

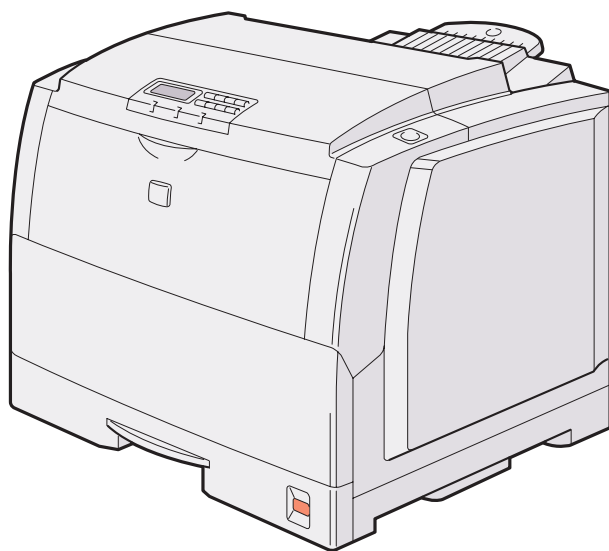

Read this manual carefully before you use this product and keep it handy for future reference.

For safety, please follow the instructions in this manual.



RICOH COMPANY, LTD.

15-5, 1 chome, Minami-Aoyama, Minato-ku, Tokyo
Telephone: Tokyo 3479-3111

Overseas Affiliates

U.S.A.

RICOH CORPORATION
5 Dedrick Place
West Caldwell, New Jersey 07006
Phone: +1-973-882-2000

The Netherlands

RICOH EUROPE B.V.
Groenelaan 3, 1186 AA, Amstelveen
Phone: +31-(0)20-5474111

United Kingdom

RICOH UK LTD.
RicoH House,
1 Plane Tree Crescent, Feltham,
Middlesex, TW13 7HG
Phone: +44-(0)181-261-4000

Germany

RICOH DEUTSCHLAND GmbH
Mergenthalerallee 38-40,
65760 Eschborn
Phone: +49-(0)6196-9060

France

RICOH FRANCE S.A.
383, Avenue du Général de Gaulle
BP 307-92143 Clamart Cedex
Phone: +33-(0)1-40-94-38-38

Spain

RICOH ESPAÑA S.A.
Avda. Litoral Mar, 12-14,
08005 Barcelona
Phone: +34-(0)93-295-7600

Italy

RICOH ITALIA SpA
Via della Metallurgia 12,
37139 Verona
Phone: +39-(0)45-8181500

Hong Kong

RICOH HONG KONG LTD.
23/F., China Overseas Building,
139, Hennessy Road,
Wan Chai, Hong Kong
Phone: +852-2862-2888

Singapore

RICOH ASIA PACIFIC PTE.LTD.
260 Orchard Road,
#15-01/02 The Heeren,
Singapore 238855
Phone: +65-830-5888

Model number: G024-17

Printed in Japan

UE  G024-8637

Introduction

This manual contains detailed instructions on the operation and maintenance of this machine. To get maximum versatility from this machine all operators should carefully read and follow the instructions in this manual. Please keep this manual in a handy place near the machine.

Please read the Safety Information before using this machine. It contains important information related to USER SAFETY and PREVENTING EQUIPMENT PROBLEMS.

Power Source

120 V, 60 Hz, 10 A or more

Please be sure to connect the power cord to a power source as above.

Operator Safety:

This machine is considered a CDRH class I laser device, safe for office/ EDP use. The machine contains 10-milliwatt, 760 - 800 nanometer wavelength, GaAlAs laser diode. Direct (or indirect reflected) eye contact with the laser beam might cause serious eye damage. Safety precautions and interlock mechanisms have been designed to prevent any possible laser beam exposure to the operator.

Laser Safety:

The Center for Devices and Radiological Health (CDRH) prohibits the repair of laser-based optical unit in the field. The optical housing unit can only be repaired in a factory or at a location with the requisite equipment. The laser subsystem is replaceable in the field by a qualified Customer Engineer. The laser chassis is not repairable in the field. Customer engineers are therefore directed to return all chassis and laser subsystems to the factory or service depot when replacement or the optical subsystem is required.

Important

Parts of this manual are subject to change without prior notice. In no event will the company be liable for direct, indirect, special, incidental, or consequential damages as a result of handling or operating the machine.

Caution:

Use of controls or adjustment or performance of procedures other than those specified in this manual might result in hazardous radiation exposure.

Do not attempt any maintenance or troubleshooting other than that mentioned in this manual. This machine contains a laser beam generator and direct exposure to laser beams can cause permanent eye damage.

Two kinds of size notation are employed in this manual. With this machine refer to the inch version.

Ricoh shall not be responsible for any damage or expense that might result from the use of parts other than genuine Ricoh parts in your Ricoh office product.

For good copy quality, Ricoh recommends that you use genuine Ricoh toner.

Note to users in the United States of America

Notice:

This equipment has been tested and found to comply with the limits for a Class B digital device, pursuant to Part 15 of the FCC Rules. These limits are designed to provide reasonable protection against harmful interference in a residential installation. This equipment generates, uses and can radiate radio frequency energy and, if not installed and used in accordance with the instructions, may cause harmful interference to radio communications.

However, there is no guarantee that interference will not occur in a particular installation. If this equipment does cause harmful interference to radio or television reception, which can be determined by turning the equipment off and on, the user is encouraged to try to correct the interference by one more of the following measures:

Reorient or relocate the receiving antenna.

Increase the separation between the equipment and receiver.

Connect the equipment into an outlet on a circuit different from that to which the receiver is connected.

Consult the dealer or an experienced radio/TV technician for help.

Warning

Changes or modifications not expressly approved by the party responsible for compliance could void the user's authority to operate the equipment.

Caution (in case of 100BaseTX environment):

Properly shielded and grounded cables (STP) and connectors must be used for connections to host computer (and/or peripheral) in order to meet FCC emission limits.

Declaration of Conformity

Product Name: Printer

Model Number: G024-17

Responsible party: Ricoh Corporation

Address: 5 Dedrick Place, West Caldwell, NJ 07006

Telephone number: 973-882-2000

This device complies with part 15 of FCC Rules.

Operation is subject to the following two conditions:

1. This device may not cause harmful interference, and
2. this device must accept any interference received, including interference that may cause undesired operation.

Properly shielded cables must be used for connections to host computer (and/or peripheral) in order to meet FCC emission limits.

Network interface cable with ferrite core must be used for RF interference suppression.

Note to users in Canada

Note:

This Class B digital apparatus complies with Canadian ICES-003.

Remarque concernant les utilisateurs au Canada

Avertissement:

Cet appareil numérique de la classe B est conforme à la norme NMB-003 du Canada.

In accordance with IEC 60417, this machine uses the following symbols for the main power switch:

I means POWER ON.

O means POWER OFF.

Introduction

This manual contains detailed instructions on the operation and maintenance of this machine. To get maximum versatility from this machine all operators should carefully read and follow the instructions in this manual. Please keep this manual in a handy place near the machine.

Please read the Safety Information before using this machine. It contains important information related to USER SAFETY and PREVENTING EQUIPMENT PROBLEMS.

Power Source

120 V, 60 Hz, 10 A or more

Please be sure to connect the power cord to a power source as above.

Operator Safety:

This machine is considered a CDRH class I laser device, safe for office/ EDP use. The machine contains 10-milliwatt, 760 - 800 nanometer wavelength, GaAlAs laser diode. Direct (or indirect reflected) eye contact with the laser beam might cause serious eye damage. Safety precautions and interlock mechanisms have been designed to prevent any possible laser beam exposure to the operator.

Laser Safety:

The Center for Devices and Radiological Health (CDRH) prohibits the repair of laser-based optical unit in the field. The optical housing unit can only be repaired in a factory or at a location with the requisite equipment. The laser subsystem is replaceable in the field by a qualified Customer Engineer. The laser chassis is not repairable in the field. Customer engineers are therefore directed to return all chassis and laser subsystems to the factory or service depot when replacement or the optical subsystem is required.

Important

Parts of this manual are subject to change without prior notice. In no event will the company be liable for direct, indirect, special, incidental, or consequential damages as a result of handling or operating the machine.

Caution:

Use of controls or adjustment or performance of procedures other than those specified in this manual might result in hazardous radiation exposure.

Do not attempt any maintenance or troubleshooting other than that mentioned in this manual. This machine contains a laser beam generator and direct exposure to laser beams can cause permanent eye damage.

Two kinds of size notation are employed in this manual. With this machine refer to the inch version.

Savin shall not be responsible for any damage or expense that might result from the use of parts other than genuine Savin parts in your Savin office product.

For good copy quality, Savin recommends that you use genuine Savin toner.

Note to users in the United States of America

Notice:

This equipment has been tested and found to comply with the limits for a Class B digital device, pursuant to Part 15 of the FCC Rules. These limits are designed to provide reasonable protection against harmful interference in a residential installation. This equipment generates, uses and can radiate radio frequency energy and, if not installed and used in accordance with the instructions, may cause harmful interference to radio communications.

However, there is no guarantee that interference will not occur in a particular installation. If this equipment does cause harmful interference to radio or television reception, which can be determined by turning the equipment off and on, the user is encouraged to try to correct the interference by one more of the following measures:

Reorient or relocate the receiving antenna.

Increase the separation between the equipment and receiver.

Connect the equipment into an outlet on a circuit different from that to which the receiver is connected.

Consult the dealer or an experienced radio/TV technician for help.

Warning

Changes or modifications not expressly approved by the party responsible for compliance could void the user's authority to operate the equipment.

Caution (in case of 100BaseTX environment):

Properly shielded and grounded cables (STP) and connectors must be used for connections to host computer (and/or peripheral) in order to meet FCC emission limits.

Declaration of Conformity

Product Name: Printer

Model Number: G024-17

Responsible party: Ricoh Corporation

Address: 5 Dedrick Place, West Caldwell, NJ 07006

Telephone number: 973-882-2000

This device complies with part 15 of FCC Rules.

Operation is subject to the following two conditions:

1. This device may not cause harmful interference, and
2. this device must accept any interference received, including interference that may cause undesired operation.

Properly shielded cables must be used for connections to host computer (and/or peripheral) in order to meet FCC emission limits.

Network interface cable with ferrite core must be used for RF interference suppression.

Note to users in Canada

Note:

This Class B digital apparatus complies with Canadian ICES-003.

Remarque concernant les utilisateurs au Canada

Avertissement:

Cet appareil numérique de la classe B est conforme à la norme NMB-003 du Canada.

In accordance with IEC 60417, this machine uses the following symbols for the main power switch:

I means **POWER ON.**

O means **POWER OFF.**

Introduction

This manual contains detailed instructions on the operation and maintenance of this machine. To get maximum versatility from this machine all operators should carefully read and follow the instructions in this manual. Please keep this manual in a handy place near the machine.

Please read the Safety Information before using this machine. It contains important information related to USER SAFETY and PREVENTING EQUIPMENT PROBLEMS.

Power Source

120 V, 60 Hz, 10 A or more

Please be sure to connect the power cord to a power source as above.

Operator Safety:

This machine is considered a CDRH class I laser device, safe for office/ EDP use. The machine contains 10-milliwatt, 760 - 800 nanometer wavelength, GaAlAs laser diode. Direct (or indirect reflected) eye contact with the laser beam might cause serious eye damage. Safety precautions and interlock mechanisms have been designed to prevent any possible laser beam exposure to the operator.

Laser Safety:

The Center for Devices and Radiological Health (CDRH) prohibits the repair of laser-based optical unit in the field. The optical housing unit can only be repaired in a factory or at a location with the requisite equipment. The laser subsystem is replaceable in the field by a qualified Customer Engineer. The laser chassis is not repairable in the field. Customer engineers are therefore directed to return all chassis and laser subsystems to the factory or service depot when replacement or the optical subsystem is required.

Important

Parts of this manual are subject to change without prior notice. In no event will the company be liable for direct, indirect, special, incidental, or consequential damages as a result of handling or operating the machine.

Caution:

Use of controls or adjustment or performance of procedures other than those specified in this manual might result in hazardous radiation exposure.

Do not attempt any maintenance or troubleshooting other than that mentioned in this manual. This machine contains a laser beam generator and direct exposure to laser beams can cause permanent eye damage.

Two kinds of size notation are employed in this manual. With this machine refer to the inch version.

Gestetner shall not be responsible for any damage or expense that might result from the use of parts other than genuine Gestetner parts in your Gestetner office product.

For good copy quality, Gestetner recommends that you use genuine Gestetner toner.

Note to users in the United States of America

Notice:

This equipment has been tested and found to comply with the limits for a Class B digital device, pursuant to Part 15 of the FCC Rules. These limits are designed to provide reasonable protection against harmful interference in a residential installation. This equipment generates, uses and can radiate radio frequency energy and, if not installed and used in accordance with the instructions, may cause harmful interference to radio communications.

However, there is no guarantee that interference will not occur in a particular installation. If this equipment does cause harmful interference to radio or television reception, which can be determined by turning the equipment off and on, the user is encouraged to try to correct the interference by one more of the following measures:

Reorient or relocate the receiving antenna.

Increase the separation between the equipment and receiver.

Connect the equipment into an outlet on a circuit different from that to which the receiver is connected.

Consult the dealer or an experienced radio/TV technician for help.

Warning

Changes or modifications not expressly approved by the party responsible for compliance could void the user's authority to operate the equipment.

Caution (in case of 100BaseTX environment):

Properly shielded and grounded cables (STP) and connectors must be used for connections to host computer (and/or peripheral) in order to meet FCC emission limits.

Declaration of Conformity

Product Name: Printer

Model Number: G024-17

Responsible party: Ricoh Corporation

Address: 5 Dedrick Place, West Caldwell, NJ 07006

Telephone number: 973-882-2000

This device complies with part 15 of FCC Rules.

Operation is subject to the following two conditions:

1. This device may not cause harmful interference, and
2. this device must accept any interference received, including interference that may cause undesired operation.

Properly shielded cables must be used for connections to host computer (and/or peripheral) in order to meet FCC emission limits.

Network interface cable with ferrite core must be used for RF interference suppression.

Note to users in Canada

Note:

This Class B digital apparatus complies with Canadian ICES-003.

Remarque concernant les utilisateurs au Canada

Avertissement:

Cet appareil numérique de la classe B est conforme à la norme NMB-003 du Canada.

In accordance with IEC 60417, this machine uses the following symbols for the main power switch:

I means **POWER ON.**

O means **POWER OFF.**

Trademarks

Windows[®], and Windows NT[®] are registered trademarks of Microsoft Corporation in the United States and/or other countries.

PostScript[®] is a registered trademark of Adobe Systems, Incorporated.

AppleTalk is registered trademarks of Apple Computer, Incorporated.

Other product names used herein are for identification purposes only and might be trademarks of their respective companies. We disclaim any and all rights in those marks.

Notes:

Some illustrations might be slightly different from your machine.

Certain options might not be available in some countries. For details, please contact your local dealer.

Notes:

The proper names of the Windows operating systems are as follows:



- Microsoft[®] Windows[®] 95 operating system
- Microsoft[®] Windows[®] 98 operating system
- Microsoft[®] Windows NT[®] Server network operating system Version 4.0
- Microsoft[®] Windows NT[®] Workstation operating system Version 4.0

Safety Information

When using your equipment, the following safety precautions should always be followed.

Safety During Operation

In this manual, the following important symbols are used:

- | |
|--|
| <p> WARNING:
<i>Indicates a potentially hazardous situation which, if instructions are not followed, could result in death or serious injury.</i></p> <p> CAUTION:
<i>Indicates a potentially hazardous situation which, if instructions are not followed, may result in minor or moderate injury or damage to property.</i></p> |
|--|

⚠ WARNING:

- ***Connect the power cord directly into a wall outlet and never use an extension cord.***
- ***Disconnect the power plug (by pulling the plug, not the cable) if the power cable or plug becomes frayed or otherwise damaged.***
- ***To avoid hazardous electric shock or laser radiation exposure, do not remove any covers or screws other than those specified in this manual.***
- ***Turn off the power and disconnect the power plug (by pulling the plug, not the cable) if any of the following conditions exists:***
 - ***You spill something into the equipment.***
 - ***You suspect that your equipment needs service or repair.***
 - ***Your equipment's cover has been damaged.***
- ***Do not incinerate spilled toner or used toner. Toner dust might ignite when exposed to an open flame.***
- ***Disposal can take place at our authorized dealer or at appropriate collection sites.***
- ***If you dispose of the used toner containers yourself, dispose of them according to your local regulations.***

⚠ CAUTION:

- *Protect the equipment from dampness or wet weather, such as rain, snow, and so on.*
- *Unplug the power cord from the wall socket before you move the equipment. While moving the equipment, you should take care that the power cord will not be damaged under the equipment.*
- *When you disconnect the power plug from the wall socket, always pull the plug (not the cable).*
- *Do not allow paper clips, staples, or other small metallic objects to fall inside the equipment.*
- *Do not eat or swallow toner.*
- *Keep toner (used or unused) and toner cartridge out of reach of children.*
- *For environmental reasons, do not dispose of the equipment or expended supply's wastes at a household waste a collection point. Disposal can take place at our authorized dealer or at an appropriate collection site.*
- *Our products are engineered to meet the highest standards of quality and functionality. When purchasing expendable supplies, we recommend using only those specified by an authorized dealer.*
- *The inside of the machine could be very hot. Do not touch the parts with a label indicating the "hot surface". Otherwise, it could cause a personal burn.*
- *If you use this printer in a cold area, leave the printer on. Otherwise, severe cold might damage sensitive components inside the printer.*

Energy Star Program

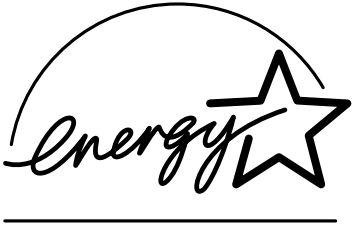
	<p>As an ENERGY STAR Partner, we have determined that this machine model meets the ENERGY STAR Guidelines for energy efficiency.</p>
---	--

The ENERGY STAR Guidelines intend to establish an international energy-saving system for developing and introducing energy-efficient office equipment to deal with environmental issues, such as global warming.

When a product meets the ENERGY STAR Guidelines for energy efficiency, the Partner shall place the ENERGY STAR logo onto the machine model.

This product was designed to reduce the environmental impact associated with office equipment by means of energy-saving features, such as Low-power mode.

❖ **Low-power mode (Energy Save mode)**

This printer automatically lowers its power consumption 60 minutes after the last operation has been completed when the Energy Save mode is set to level 1. To exit Low-power (Energy Save) mode, press any key on the operation panel. To change the setting of the Energy Save mode, see the “Getting Started”.

❖ **Specifications**

Lower-power mode (Energy Save mode)	Power Consumption	45W or less
	Default Time	60 minutes

.....

 **Recycled Paper**

Please contact your sales or service representative for recommended recycled paper types that may be used in this machine.

.....

Manuals for Your Printer

Manuals for Your Printer

There are four manuals that describe the procedures separately for the installation of your printer and for the operation and maintenance of your printer and its optional equipment.

To enhance safe and efficient operation of your printer, all users should read and follow the instructions contained in the following manuals.

❖ **Quick Installation Guide**

Describes the procedures for installing your printer.

❖ **Getting Started**

Describes how to install software to enable users to print. Specifically, it describes installation of PostScript printer drivers, printer description files, and other software provided on the CD-ROM that comes with the printer. It also explains how to connect each user to the network.

❖ **User's Guide**

Provides an introduction to desktop color printing, how to print from various computers and workstations, what you need to know about using the printer in a networked environment, and how to use the software provided.

❖ **Printer Reference (this manual)**

Describes the procedures and necessary information on setting up and using your printer and its optional equipment.

How to Read this Manual

Symbols

In this manual, the following symbols are used:

 **WARNING:**

This symbol indicates a potentially hazardous situation which, if instructions are not followed, could result in death or serious injury.

 **CAUTION:**

This symbol indicates a potentially hazardous situation which, if instructions are not followed, may result in minor or moderate injury or damage to property.

* The statements above are notes for your safety.

 **Important**

If this instruction is not followed, paper might be misfed, originals might be damaged, or data might be lost. Be sure to read this.

 **Preparation**

This symbol indicates the prior knowledge or preparations required before operating.

 **Note**

This symbol indicates precautions for operation, or actions to take after misoperation.

 **Limitation**

This symbol indicates numerical limits, functions that cannot be used together, or conditions in which a particular function cannot be used.

 **Reference**

This symbol indicates a reference.

[]

Keys that appear on the machine's panel display.

Keys and buttons that appear on the computer's display.

【 】

Keys built into the machine's operation panel.

Keys on the computer's keyboard.

TABLE OF CONTENTS

1. Getting Acquainted

Guide to the Printer	1
Exterior-Front View	1
Exterior-Rear View	3
Interior	4
Operation Panel	5
Turning the Printer On and Off	6
Turning On the Printer.....	6
Turning Off the Printer.....	6

2. Installing Options

Available Options	8
Installing the Memory Unit Type505 (DIMM)	9
Installing the Printer Hard Disk Type505	11
Installing the Paper Feed Unit Type305	13

3. Paper and Other Media

Paper and Other Media Supported by this Printer	15
Paper Types and Sizes	15
Precautions for Paper	20
Printable Area	24
Loading Paper	25
Loading Paper in the Paper Tray	25
Loading Paper in the Bypass Tray	27
Sliding out the Output Tray Extender	28

4. Troubleshooting

Error & Status Messages on the Operation Panel	29
Printer Doesn't Print	32
Other Printing Problems	35
Removing Misfed Paper	38
When the Message "REMOVE MISFEED FROM INPUT TRAY" Appears	39
When the Message "OPEN FRONT COVER REMOVE MISFEED" Appears ..	39
When the Message "REMOVE MISFEED FROM OUTPUT TRAY" Appears...	40

- Cleaning the Printer 42**
 - Cleaning the Friction Pad 42
 - Cleaning the Charger 42
 - Cleaning the Dust-proofing glass 43
- Replacing Consumables..... 45**
 - Replacing the Toner Cartridge 45
 - Replacing the Photoconductor Unit..... 48
 - Replacing the Fuser Oil Bottle and Ozone Filter 50
 - Replacing the Waste Toner Bottle and Charger 53

5. Appendix

- Moving and Transporting the Printer 55**
- Specifications 56**
 - Mainframe 56
 - Options 59
- Consumables 60**
- INDEX..... 62**

1. Getting Acquainted

Guide to the Printer

Exterior-Front View

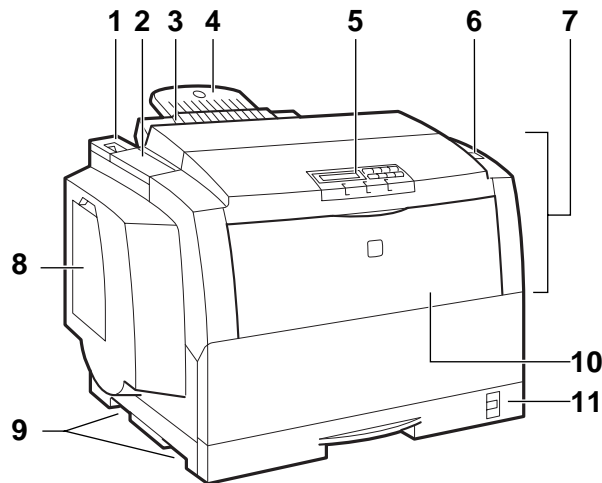

TFWX020E

1. Power Switch

Use this switch to turn printer power on and off.

2. Fuser Oil Bottle Cover

Open this cover when replacing the fuser oil bottle.

3. Output Tray

Printed pages are stacked here.

4. Output Tray Extender

Pull out this extender when printing on long paper.

5. Operation Panel

Contains keys for printer operation and a panel display that shows the printer status.

6. Front Cover Release Button

Use this button to open the front cover.

7. Front Cover

Open this cover when accessing the inside of the printer.

8. Left Cover

Open this cover when replacing the toner cartridge.

9. Inset Grips

Hold the printer at the location indicated in the illustration when transporting it. Note that there are four grips, two on the left side and two on the right side of the printer.

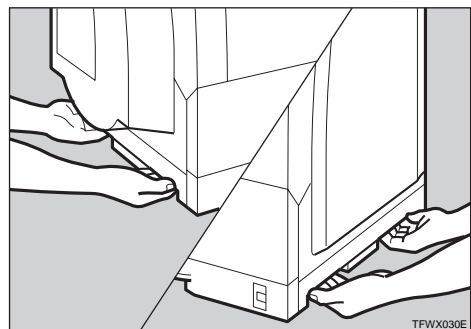

TFWX030E

10. Bypass tray

Use to print on to thick paper, OHP transparencies and adhesive labels in addition to plain paper.

1

11. Paper Tray

Load paper into this tray for printing.

Exterior-Rear View

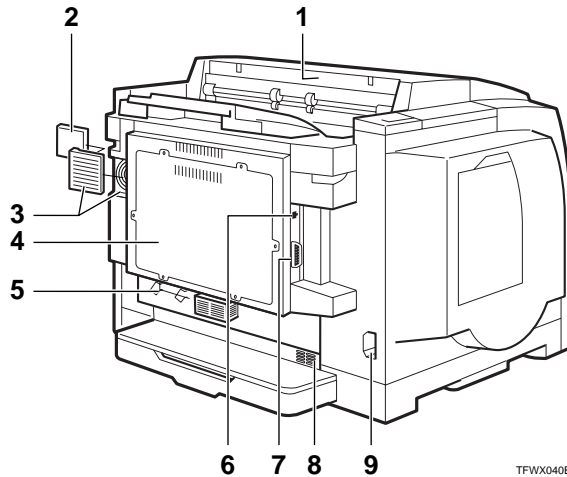

1. Paper Exit Cover

Open this cover when removing misfed paper at the fusing unit.

2. Ozone Filter

This filter reduces the amount of ozone that is discharged into the air.

3. Ventilator

This hole allow air to circulate, preventing components inside the printer from overheating.

Important

- Do not leave the ventilator obstructed or blocked. Doing so creates the danger of malfunction due to overheating.

4. Back Plate

Remove to install some options.

5. Parallel Interface Connector

Plug the interface cable that connects the printer to your computer into this connector.

Important

- Rating voltage of the parallel interface connector for the computer; Max. DC 5V.

6. Network Interface Connector for 10BASE-T/100BASE-TX

Plug the network interface cable for 10BASE-T/100BASE-TX that connects the printer to the network into this connector.

Important

- Rating voltage of the network interface connector for 10BASE-T/100BASE-TX; Max. DC5V.

7. Network Interface Connector for 10BASE5

Plug the network interface cable for 10BASE5 that connects the printer to the network into this connector.

Important

- Rating voltage of the network interface connector for 10BASE5; Max. DC12V.

8. Ventilator

This hole allow air to circulate, preventing components inside the printer from overheating.

Important

- Do not leave the ventilator obstructed or blocked. Doing so creates the danger of malfunction due to overheating.

9. Power Connector

Connect the power cord to this connector.

Interior

1

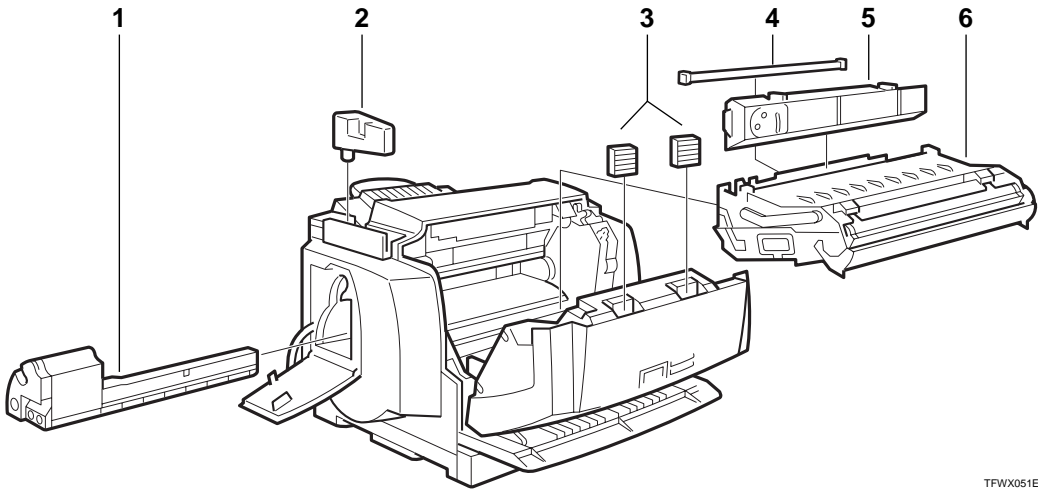

TFWX051E

1. Toner Cartridge

2. Fuser Oil Bottle

This bottle holds oil used for fusing toner to the paper.

3. Ozone Filters

These filters reduce the amount of ozone that is discharged into the air.

4. Charger

5. Waste Toner Bottle

This bottle is a receptacle for waste toner generated during the printing process.

6. Photoconductor Unit

This contains a photoconductor unit that is used to compose the image being printed.

- ❑ Do not rotate the gear on the right side of the printer. Otherwise, the inside belt gets damaged.

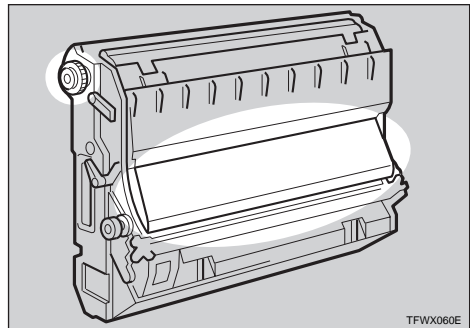

TFWX060E

Note

- ❑ Screws are used to hold the photoconductor unit in place. Be sure to remove the screws before attempting to remove the unit.
- ❑ The condition of the photoconductor unit belt directly affects output appearance and quality. Always be careful to prevent the green film in this unit from becoming dirty or damaged. And do not touch the black belt.

Operation Panel

Important

- Never press any operation panel keys while the **Data In** indicator is flashing on the operation panel.

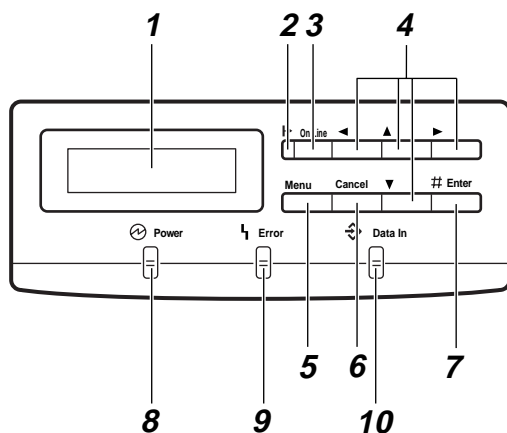

TFWS010E

1. Panel Display

The display shows the current status of the printer and error messages. ⇒ P.29 “Error & Status Messages on the Operation Panel”

2. On Line indicator

Tells you whether the printer is on-line or off-line.

Stays on while the printer is on-line (a state in which the printer can receive data from the computer).

Stays off when the printer is off-line (a state in which printer cannot receive data).

3. [On Line] key

Press this key to switch the printer between on-line and off-line conditions.

4. [◀][▲][▶][▼] keys

Use these keys to select values on the panel display when making settings.

5. [Menu] key

Press this key to make and check the printer settings.

6. [Cancel] key

Pressing this key cancels the ongoing print job.

7. [Enter] key

Press this key to execute menu items selected on the panel display.

8. Power indicator

Stays on while the printer power is on. Stays off when the power is turned off or while the printer is in the Energy Save mode.

Blinks while the printer is warming up.

9. Error indicator

Lights up whenever any printer error occurs. A message describing the cause of the error also appears on the panel display. ⇒ P.29 “Error & Status Messages on the Operation Panel”

10. Data In indicator

Blinks while the printer is communicating via the network with the network utility of client computers.

Turning the Printer On and Off

1

Turning On the Printer

- 1 Make sure that the power cord is securely plugged into the wall socket and the printer.
- 2 Set the printer's power switch to the On position.

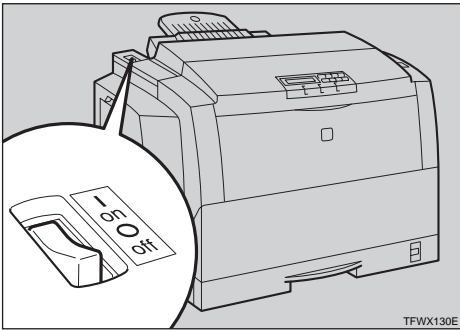

After turning on the printer, it takes about eight minutes to warm up before being able to print.

When the printer is turned on, the **Power** indicator will blink repeatedly. Once it stops blinking and remains on, you will be able to send data from the computer to the printer. When the following message appears on the operation panel, the printer will be able to begin printing.



Turning Off the Printer

- 1 Confirm that the Data In and the Error indicators are off.

 **Note**

- The **Data In** indicator blinks while receiving and printing data from the computer and remains lit when printing. Do not turn off the printer while it is blinking.
- When the **Error** indicator lights up, a printer error has occurred. Use the message that appears on the operation panel to troubleshoot the problem.

- 2 Set the printer's power switch to the Off position.

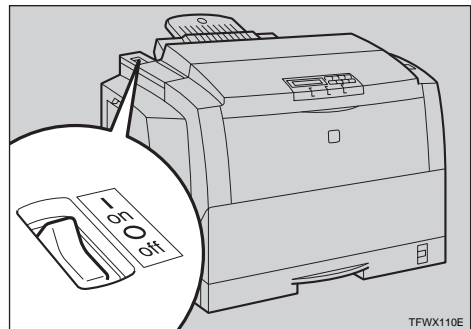

The **Power** indicator turns off.

 **Note**

- After printing, wait for about two minutes before turning off the printer. The printer uses this time to maintain itself. Turning off the printer immediately after printing may, over time, reduce the print quality.

2. Installing Options

⚠ CAUTION:

- *Make sure to turn off the printer and wait for about 30 minutes before installing options. Not waiting for the printer to cool down can result in a burn.*
- *It is recommended that at least two persons are used to lift the machine. Otherwise, the machine might fall and cause personal injury.*
- *When lifting the machine, use the inset grips on both sides of the machine. Otherwise, the machine might fall and cause personal injury.*
- *When you move the machine, unplug the power cord from the wall socket to avoid a fire or an electric shock.*

Available Options

The following options can be installed to your printer.

Reference

For more information on the options, see P.59 “Options”. Do not use options other than those specified in this manual.

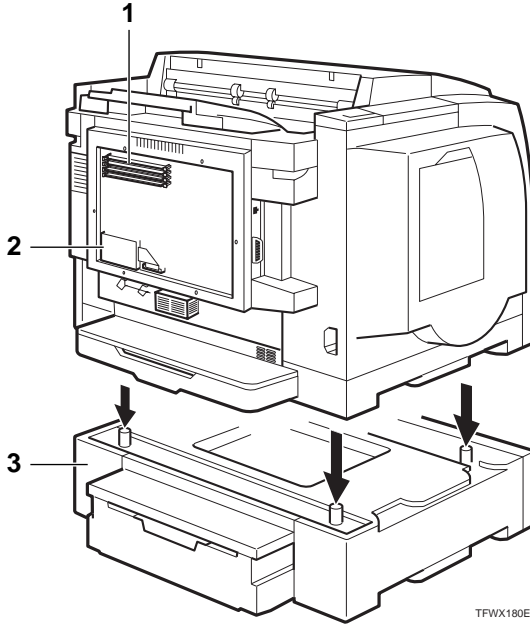

1. Memory Unit Type505 ⇒ P.9

- Memory Unit Type505 (32MB) (DIMM)
- Memory Unit Type505 (64MB) (DIMM)

2. Printer Hard Disk Type505 ⇒ P.11

3. Paper Feed Unit Type305 ⇒ P.13

Note

- ❑ It is impossible to install more than two paper feed units to your printer at a time.

Installing the Memory Unit Type505 (DIMM)

⚠ CAUTION:

- Make sure to turn off the printer and wait for about 30 minutes before installing options. Not waiting for the printer to cool down can result in a burn.

⚡ Important

- ❑ The memory unit can be damaged by small amounts of static electricity. Before touching it, touch something metal to discharge static electricity from you.

1 Turn off the printer's power switch and remove all cables and cords from the printer.

2 Remove screws and remove the back plate.

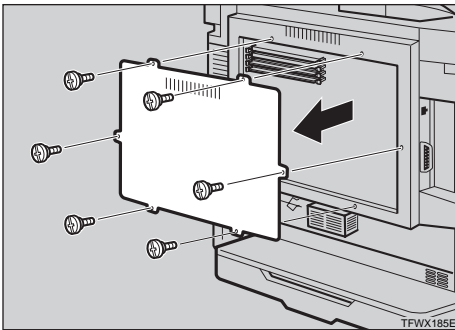

🔧 Note

- ❑ A coin can be used to remove the screws.

3 Open the white tabs, which hold the memory, to their widest position (①). Insert the memory unit horizontally into the slot (②). Push it in and then close the white tabs (③).

🔧 Note

- ❑ There are two notches on the side with the connector of the memory unit. They are located on the left and in the center. Be sure to align the notches over the guides correctly, as shown in the illustration.

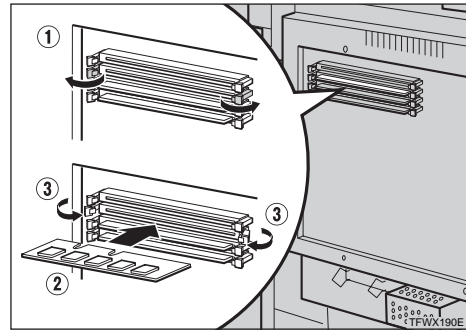

4 Attach the back plate to its original position, and fasten it with screws that were removed in step 2.

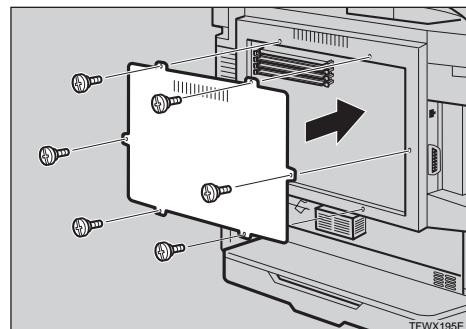

🔧 Note

- ❑ A coin can be used to fasten the screws.

5 Plug the printer's power cord back into the printer and the wall socket. Turn on the printer's power switch.

6 Print a configuration page to confirm that the memory unit is properly installed.

 **Reference**

For more information on the configuration page, see the "Getting Started".

 **Note**

- If the memory unit is not properly installed, repeat steps **1** to **6** again. If you fail again, contact your sales or service representative.

Installing the Printer Hard Disk Type505

⚠ CAUTION:

- Make sure to turn off the printer and wait for about 30 minutes before installing options. Not waiting for the printer to cool down can result in a burn.

🔧 Note

- For this printer, use only Printer Hard Disk Type505.

1 Check the contents of the box for the following items.

- Printer Hard Disk Type505
- Installation Guide
- Screws (3 pcs)

2 Turn off the printer's power switch and remove all cables and cords from the printer.

3 Remove screws and remove the back plate.

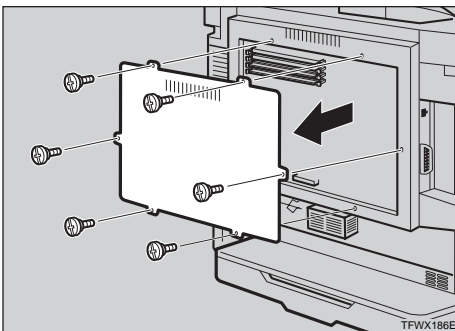

🔧 Note

- A coin can be used to remove the screws.

4 Make sure that the projection of the connector of the hard disk is on the top. Attach the connector to the slot while holding the hard disk.

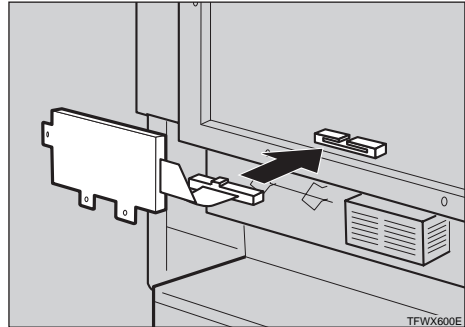

5 Set the hard disk in the lower left corner at the rear of the printer, as shown in the illustration. Make sure that the screw holes of the hard disk align with the screw holes of the printer. And fasten it with the screws that are enclosed in the box using the screw driver.

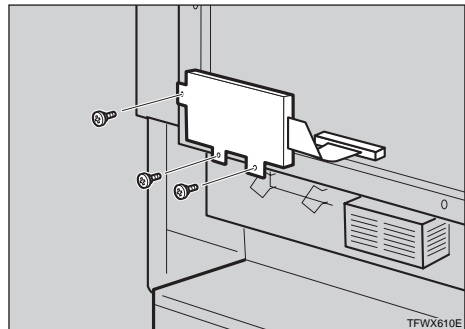

- 6** Attach the back plate to its original position, and fasten it with screws that were removed in step **3**.

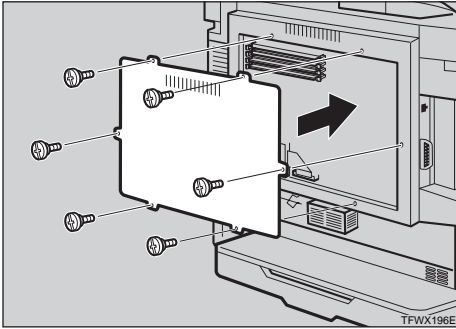

Note

- A coin can be used to fasten the screws.

- 7** Plug the printer's power cord back into the printer and the wall socket. Turn on the printer's power switch.

- 8** After installing the hard disk, initialize it using the operation panel.

The following message appears on the panel display.

```
PRESS ENTER TO
INITIALIZE DISK
```

- 9** Press **[Enter]**.

The printer starts initializing the hard disk. The following message appears on the panel display.

```
INITIALIZING
```

- 10** When initialization finishes, the following message appears on the panel display.

```
READY
```

- 11** Print a configuration page to confirm that the hard disk is properly installed.

Reference

For more information on the configuration page, see the "Getting Started".

Note

- If the hard disk is not properly installed, repeat steps **2** to **11** again. If you fail again, contact your sales or service representative.

Important

- To make the printer recognize the installed option properly, you must set up the option with the printer driver. See the "User's Guide" for further details.

Installing the Paper Feed Unit Type305

⚠ CAUTION:

- It is recommended that at least two persons are used to lift the machine. Otherwise, the machine might fall and cause personal injury.
- When lifting the machine, use the inset grips on both sides of the machine. Otherwise, the machine might fall and cause personal injury.
- When moving the printer, be sure to keep it level to avoid spilling the fuser oil. If oil is spilt, wipe it with alkaline cleaner. Otherwise, the oily surfaces can create the danger of slipping and personal injury.

⚠ Important

- ❑ If your printer is equipped with the optional tray, do not pull out more than one tray with paper at a time. If you do, the printer might tilt forward.

📌 Note

- ❑ It is impossible to install more than two paper feed units to your printer at a time.

1 Check the contents of the box for the following items.

- Paper Feed Unit Type305
- Installation Guide

2 Turn off the printer's power switch and remove all cables and cords from the printer.

3 Move the printer to make installing space.

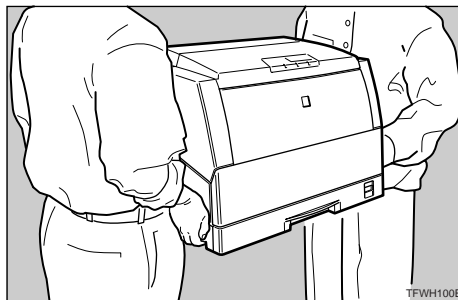

⚠ Important

- ❑ Be careful to lift the printer as the right front side of the printer is significantly heavier than the left front side.

4 Remove the paper feed unit from the box, and remove the styrofoam packing and the bag from the side covers.

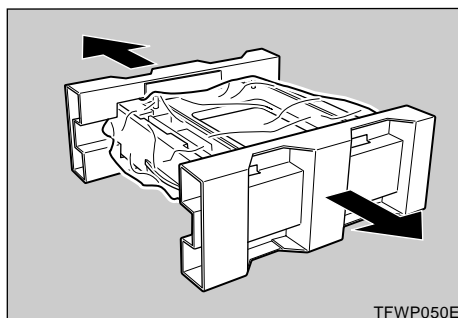

- 5** Remove both pieces of adhesive tape.

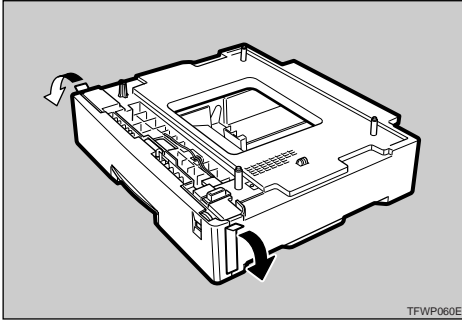

- 6** Pull out the paper tray, and remove the padding.

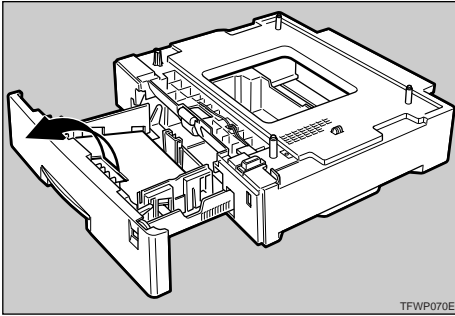

- 7** Remove the ring attached to the red tag.

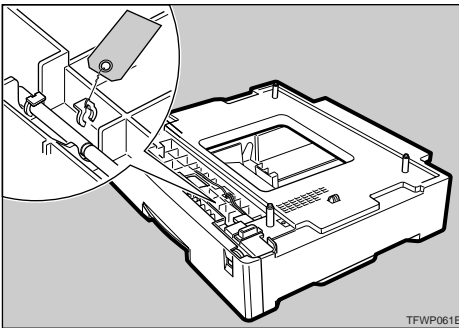

- 8** If installing two paper feed units, place one paper feed unit on the other paper feed unit at first. If installing only one paper feed unit, go to step 9.

Align the paper feed unit onto the 4 upright pins on the other paper feed unit.

- 9** Place the printer on the paper feed unit.

Align the printer onto the 4 upright pins on the paper feed unit and then lower it gently.

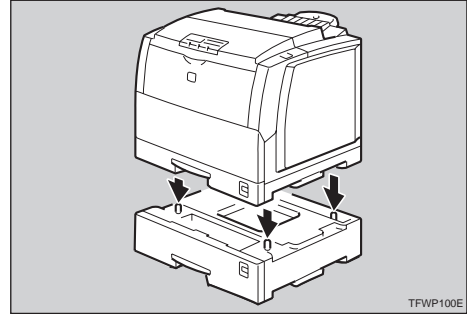

- 10** Connect all of cables that were removed in step 2.

- 11** Plug the printer's power cord back into the printer and the wall socket. Turn on the printer's power switch.

- 12** Print a configuration page to confirm that the paper feed unit is properly installed.

Reference

For more information on the configuration page, see the "Getting Started".

Note

- If the paper feed unit doesn't work, follow the above instructions to reinstall it. If it still doesn't work, contact your sales or service representative.

Important

- To make the printer recognize the installed option properly, you must set up the option with the printer driver. See the "User's Guide" for further details.
- After installing the paper feed unit properly, set up the paper size. ⇒ P.25 "Loading Paper"

3. Paper and Other Media

Paper and Other Media Supported by this Printer

Paper Types and Sizes

This section provides the type, size, feed direction, and maximum capacity of paper that can be loaded into each paper tray in this printer.

 **Note**

- The "☐" symbol means short-edge feed direction.
- The "☐" symbol means long-edge feed direction.
- The paper feed direction depends on the paper size.
- This printer can automatically switch to 8¹/₂"×11" (Letter) size paper if there is no A4 size paper available, and vice-versa. For example, if the printer has no A4 size paper when you want to print on A4, the printer searches for 8¹/₂"×11" (Letter) size paper and prints on that instead.

❖ Paper Sizes (Metric version)

	Feed direction	Size (mm)	Bypass Tray	Standard Tray (Tray 1)	Paper Feed Unit Type305 (Tray 2/3)
13" × 18"	☐	330 × 457	☆	○	×
12" × 18"	☐	305 × 457	☆	★	×
A3	☐	297 × 420	☆	○	○
B4 JIS	☐	257 × 364	☆	★ ^{*1}	★
A4	☐	210 × 297	×	×	×
	☐	297 × 210	☆ ^{*1}	○	○
B5 JIS	☐	182 × 257	×	×	×
	☐	257 × 182	☆	★	★
A5	☐	148 × 210	×	×	×
	☐	210 × 148	☆	○	×
B6 JIS	☐	128 × 182	○	×	×
A6	☐	105 × 148	☆	×	×
Double Letter (DLT, 11" × 17")	☐	279 × 432	☆	★	○
Legal (LG, 8 ¹ / ₂ " × 14")	☐	216 × 356	☆	★	○
Letter (LT, 8 ¹ / ₂ " × 11")	☐	216 × 279	×	×	×
	☐	279 × 216	☆	○	○
Half Letter (HLT, 5 ¹ / ₂ " × 8 ¹ / ₂ ")	☐	216 × 140	×	×	×
	☐	140 × 216	☆	★	×
Executive (Exec., 7 ¹ / ₄ " × 10 ¹ / ₂ ")	☐	184 × 276	×	×	×
	☐	276 × 184	☆	★	○
Folio (8 ¹ / ₄ " × 13")	☐	210 × 330	☆	★	★
Foolscap (F4, 8 ¹ / ₂ " × 13")	☐	216 × 330	☆	○	★ ^{*1}
F/GL (8" × 13")	☐	203 × 330	☆	★	★

^{*1} :Default setting for "★" on the dial.⇒ P.26 "Specifying paper size using the operation panel"

- ☆ means that the size is supported and needs to specify the paper size using the operation panel. (Regarding the bypass tray, there is no dial on the tray.)
⇒ P.27 *“Loading Paper in the Bypass Tray”*
- ○ means that the size is supported and indicated on the tray dial. Be sure to set the paper size dial to match the actual paper size loaded in the tray.
- ★ means that the size is supported but not indicated on the paper size dial. You should set the paper size dial to “✱”, and specify the paper size using the operation panel. The default setting is Foolscap (8.5"×13"). ⇒ P.26 *“Specifying paper size using the operation panel”*
- × means that the size is not supported.

The paper tray can support paper 64 – 105 g/m² (17 – 28 lb).

The bypass tray can support paper 64 – 157 g/m² (17 – 42 lb).

The optional paper tray can support paper 64 – 105 g/m² (17 – 28 lb).

❖ Paper Sizes (Inch version)

	Feed direction	Size (inch)	Bypass Tray	Standard Tray (Tray 1)	Paper Feed Unit Type305 (Tray 2/3)
13" × 18"	☐	13" × 18"	☆	★	×
12" × 18"	☐	12" × 18"	☆	○	×
Double Letter (DLT)	☐	11" × 17"	☆	○	○
Legal (LG)	☐	8 ¹ / ₂ " × 14"	☆	○	○
Letter (LT)	☐	8 ¹ / ₂ " × 11"	×	×	×
	☐	11" × 8 ¹ / ₂ "	☆ *1	○	○
Half Letter (HLT)	☐	5 ¹ / ₂ " × 8 ¹ / ₂ "	×	×	×
	☐	8 ¹ / ₂ " × 5 ¹ / ₂ "	☆	★	×
Executive (Exec.)	☐	7 ¹ / ₄ " × 10 ¹ / ₂ "	×	×	×
	☐	10 ¹ / ₂ " × 7 ¹ / ₄ "	☆	○	○
A3	☐	11.26" × 16.54"	☆	★	○
B4 JIS	☐	10.12" × 14.33"	☆	×	★
A4	☐	8.26" × 5.83"	×	×	×
	☐	5.83" × 8.26"	☆	○	○
B5 JIS	☐	7.17" × 10.12"	×	×	×
	☐	10.12" × 7.17"	☆	×	★
A5	☐	5.83" × 8.26"	×	×	×
	☐	8.26" × 5.83"	☆	×	×
B6 JIS	☐	5.04" × 7.17"	×	×	×
A6	☐	4.13" × 5.83"	☆	×	×
Folio	☐	8 ¹ / ₄ " × 13"	☆	★	★
Foolscap (F4)	☐	8 ¹ / ₂ " × 13"	☆	★ *1	★ *1
F/GL	☐	8" × 13"	☆	★	★

*1 : Default setting for "★" on the dial. ⇒ P.26 "Specifying paper size using the operation panel"

- ☆ means that the size is supported and needs to specify the paper size using the operation panel. (Regarding the bypass tray, there is no dial on the tray.)
⇒ P.27 *“Loading Paper in the Bypass Tray”*
- ○ means that the size is supported and indicated on the tray dial. Be sure to set the paper size dial to match the actual paper size loaded in the tray.
- ★ means that the size is supported but not indicated on the paper size dial. You should set the paper size dial to “✱”, and specify the paper size using the operation panel. The default setting is Foolscap (8.5"×13"). ⇒ P.26 *“Specifying paper size using the operation panel”*
- × means that the size is not supported.

The paper tray can support paper 64 – 105 g/m² (17 – 28 lb).

The bypass tray can support paper 64 – 157 g/m² (17 – 42 lb).

The optional paper tray can support paper 64 – 105 g/m² (17 – 28 lb).

Precautions for Paper

Note the following precautions when handling or selecting paper to be used with this printer.

Cautions in loading paper

Important

- Do not use paper that is meant for an inkjet printer. Otherwise, it may stick to the fusing unit and cause a paper misfeed.
 - When printing on an OHP transparency that has a print side, load it with the print side down onto the bypass tray. Otherwise, it may stick to the fusing unit and cause a misfeed.
 - Use only the recommended paper types. Print quality cannot be guaranteed if other paper types are used. ⇒ P.23 *“Paper not supported by this printer”*
 - Do not use paper that is already printed on.
-

Cautions in storing paper

Paper should always be stored properly. Improperly stored paper might result in poor print quality, paper misfeeds, or printer damage.

Follow the precautions below.

- Avoid storing paper in humid areas.
 - Avoid exposing paper to direct sunlight.
 - Store on a flat surface.
 - Keep open reams of paper in the package in which the paper came.
-

Paper types and cautions

❖ Plain paper

- The standard tray can hold up to 250 sheets. ^{*1}
- The bypass tray can hold up to 50 sheets. ^{*1}
- The Paper Feed Unit Type305 (option) can hold up to 500 sheets. ^{*1}
^{*1} : Based on paper that is 80 g/m² (metric version), 20 lb (inch version) in weight.
- If paper is curled or bent, correct it before loading.

Note

- To get the best print quality, we recommend you use paper exclusively designed for color copier.

❖ Thick Paper

- If you print on paper heavier than 105 g/m² (28 lb), use the bypass tray. The bypass tray can hold paper up to 157 g/m² (42 lb) in weight. The print quality on paper that is thicker cannot be guaranteed.
- The bypass tray can hold up to 25 sheets.

Note

- The number of sheets to be set may vary depending on the paper thickness and paper type.
- When printing on thick paper, you should select the thick paper mode with the printer driver.

❖ Adhesive labels

- When printing on adhesive labels, use the bypass tray.

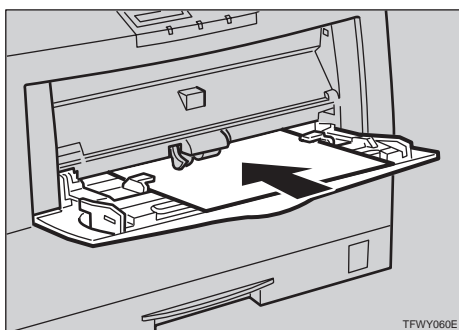

- Load adhesive labels into the tray with the print side down.
- Remove any unused adhesive labels from the tray after you are finished printing. Leaving them in the tray can cause them to curl.
- When printing on adhesive labels, you should select the plain paper mode with the printer driver.
- The bypass tray can hold up to 40 adhesive labels.

Note

- The number of sheets to be set may vary depending on the paper thickness and paper type.

❖ OHP transparencies

- When printing on OHP transparency, use the bypass tray.

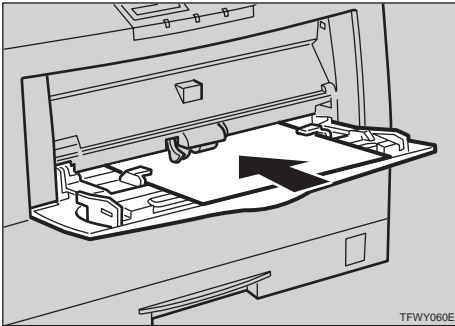

3

- Load OHP transparencies into the tray with the print side down. Otherwise, it may stick to the fusing unit and cause a misfeed.
- Remove any unused OHP transparencies from the tray after you are finished printing. Leaving them in the tray can cause them to curl.
- When printing on OHP transparencies, you should select the OHP transparency mode with the printer driver.
- The bypass tray can hold up to 50 OHP transparency sheets.

Note

- The number of sheets to be set may vary depending on the paper thickness and paper type.
- When the “OHP SLIP SHEET” setting is set to “NO”, be sure to remove each OHP transparency immediately after it is printed. For more information, see the “Getting Started”.

Note

- This printer uses paper in tray 1 for OHP slip sheet even if the direction and size of paper loaded in tray 1 is different from the direction and size of the OHP transparency. Check the direction and size of paper loaded in tray 1 before using “OHP SLIP SHEET” setting.
- When there is no paper in tray 1, “OHP SLIP SHEET” will not work even if “OHP SLIP SHEET” setting is set to “YES”. Be sure to remove each OHP transparency immediately after it is printed.

Paper not supported by this printer

Avoid using the following types of paper that are not supported by this printer:

- Paper whose weight is heavier or lighter than the limitation.
- Bent, folded, or creased paper
- Curled or twisted paper
- Torn paper
- Wrinkled paper
- Damp paper
- Paper stuck together
- Paper that is dry enough to emit static electricity
- Paper that has already been printed on (with the exception of preprinted letterhead)

 **Note**

- The ink for the format printing by a copier, or an inkjet printer and so on might do harm to the fusing unit of this printer due to a difference in fusing temperatures.
- Coated paper (except the recommended one)
- Special paper like thermal paper, aluminum foil, carbon paper and conductive paper
- Heavily textured paper
- Glued paper
- Label paper on which glue or base paper is exposed
- Paper with clips or stapled
- Paper with tape or ribbons attached
- Paper is meant for an inkjet printer.
- Envelopes

Printable Area

The following shows the printable area for this printer. Be sure to set the print margins correctly.

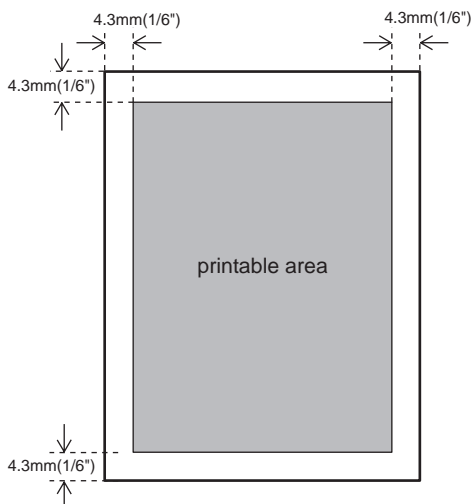

3

 **Note**

- The printable area may vary depending on paper size, printer language and printer driver settings.

Loading Paper

Loading Paper in the Paper Tray

Use the following procedure to load paper in the paper tray and optional tray. See P.27 “Loading Paper in the Bypass Tray” for details on the bypass tray.

Important

- After you load paper, you must set the paper size dial to match the actual paper size loaded in the tray. Otherwise, the printer might be damaged.

Reference

See P.15 “Paper and Other Media Supported by this Printer” for details on supported paper types and sizes.

- 1** Carefully pull the paper tray out of the printer and place it on a flat surface.

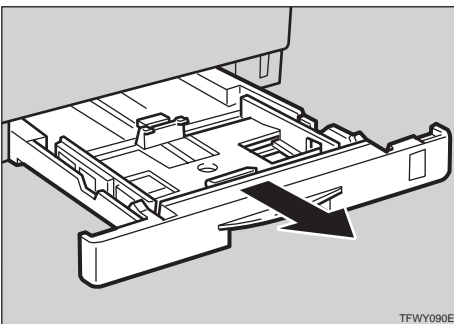

- 2** Slide the paper guides to positions that match the size of paper you want to load.

Adjust the paper guides until they click into position.

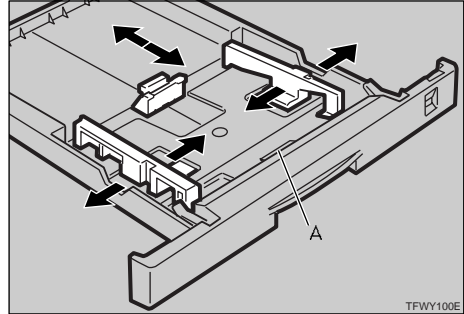

Important

- Do not touch the friction pad (A). Otherwise, paper misfeeds or paper multi-feeds might occur.

- 3** Load paper into the tray with the print side up.

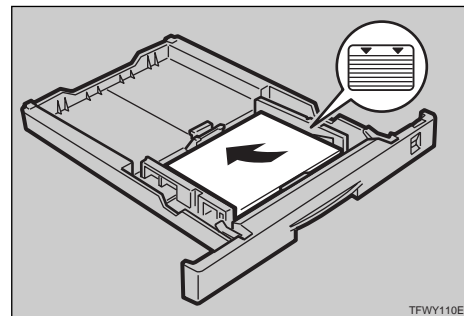

Important

- Make sure that the stack of paper is no higher than the limit mark (▼▼) inside the tray.
- Make sure the paper fits under the back paper guide.

- Adjust the paper size dial to match the size of the paper in the paper tray.

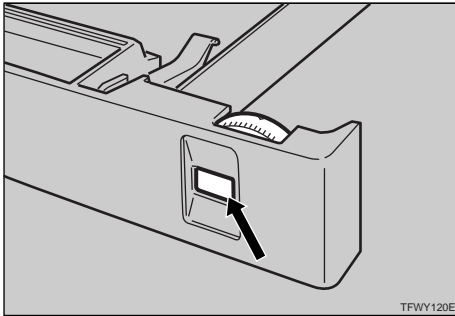

Note

- For more information about the position of the paper size dial, see P.16 "Paper Sizes (Metric version)" or P.18 "Paper Sizes (Inch version)".

- Slide the paper tray completely into the printer.

Important

- Be sure to insert the paper tray completely. Otherwise, paper misfeeds might occur.

Specifying paper size using the operation panel

Use the following procedure to specify the paper size from the printer's operation panel after loading paper with mark "✱" in the table mentioned above into tray 1, tray 2 and tray 3.

- Press **[Menu]**.

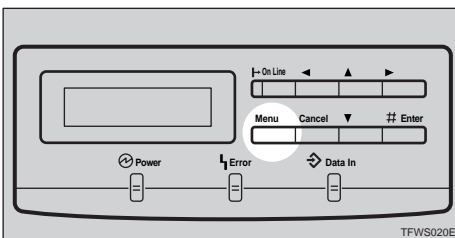

- Use **[▲]****[▼]** to display "PRINTER SETUP".



- Press **[Enter]** until "SET [*] SIZE" appears.



- Use **[▲]****[▼]** to select "YES", and then press **[Enter]** to display "TRAY1 [*] SIZE".

The currently selected paper size in paper tray appears on the panel display.

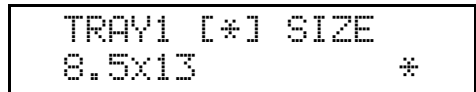

- Use **[▲]****[▼]** to select the paper size you have specified for the paper tray, and then press **[Enter]**.



- Press **[Menu]**.

The setting becomes effective.

- Press **[Menu]**.

The normal display screen appears.



Loading Paper in the Bypass Tray

Note

- Do not open the front cover when loading paper into the bypass tray.

Reference

- ⇒ P.15 "Paper Types and Sizes"
- ⇒ P.20 "Precautions for Paper"

Loading paper

- Open the bypass tray.

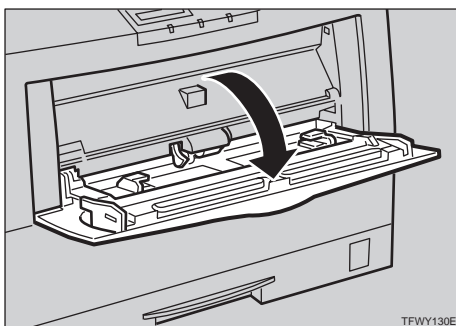

- Slide the side guides.

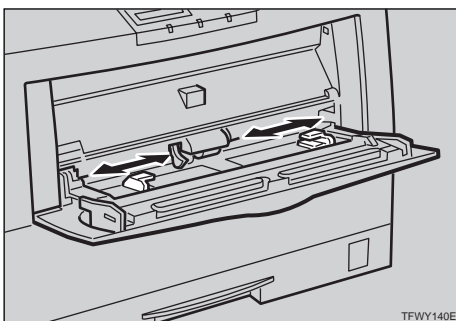

Note

- Slide out the bypass tray extender.

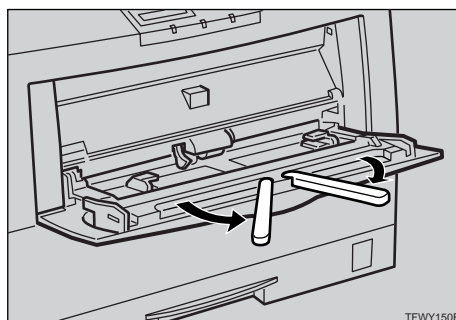

- Load paper until it stops with the print side down.

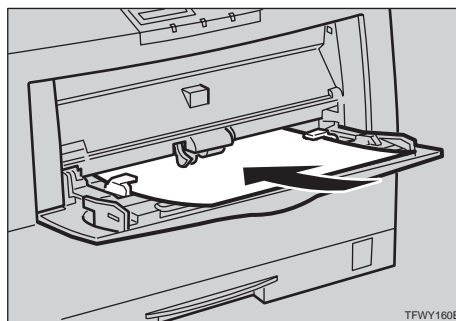

Important

- Make sure the paper fits under the side guides.
- The side guides should be set to the correct paper size to avoid paper feed problems.
- Do not load paper when printing.

Specifying paper size using the operation panel

Use the following procedure to specify the paper size from the printer's operation panel after loading paper into the bypass tray.

1 Press **[Menu]**.

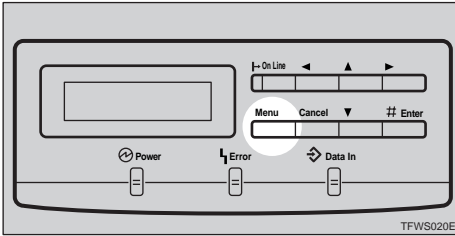

2 Use **[▲]****[▼]** to display "PRINTER SETUP".

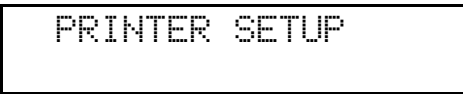

3 Press **[Enter]** until "BYPASS TRAY SIZE" appears.

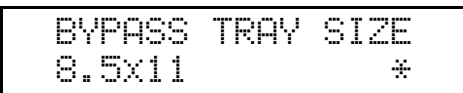

4 Use **[▲]** **[▼]** to select the paper size you have specified for the paper tray, and then press **[Enter]**.

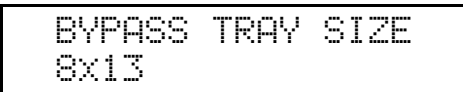

5 Press **[Menu]**.

The setting becomes effective.

6 Press **[Menu]**.

The normal display screen appears.



Sliding out the Output Tray Extender

If you load paper of A4 or 8¹/₂" × 11" or larger, slide out the output tray extender.

Important

Do not place the rear end of the printer near a wall or touch it with barehands. This area can become extremely hot.

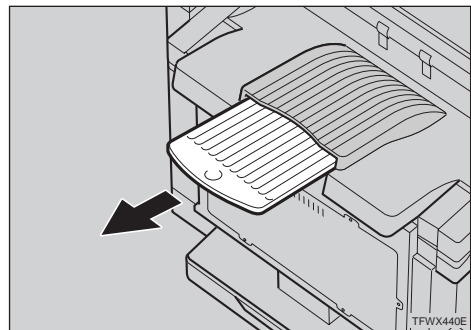

Note

After printing, return the output tray extender to its original position.

4. Troubleshooting

Error & Status Messages on the Operation Panel

Message	Description	Comments
ADD FUSER OIL	The fuser oil bottle is empty.	Replace the fuser oil bottle. ⇒ P.50 "Replacing the Fuser Oil Bottle and Ozone Filter"
CALL SERVICE SC:nn	There is a malfunction in the printer.	Turn the printer off and on. If this doesn't clear the problem, contact your sales or service representative.
CHECK CHARGER	The charger is not set correctly or the charger cleaner is not in the correct position.	Set the charger correctly. ⇒ P.53 "Replacing the Waste Toner Bottle and Charger"
CHECK FUSING UNIT	The fusing unit is not installed in the printer.	Contact your sales or service representative.
CHECK PCU	The photoconductor unit is not installed in the printer.	Install the photoconductor unit. ⇒ P.48 "Replacing the Photoconductor Unit"
CHECK TONER CARTRIDGE	The toner cartridge is not installed correctly.	Install the cartridge correctly. ⇒ P.45 "Replacing the Toner Cartridge"
CHECK WASTE TONER BOTTLE	The waste toner bottle is not installed.	Install the waste toner bottle. ⇒ P.53 "Replacing the Waste Toner Bottle and Charger"
CHECK (tray name)	The paper tray is not installed correctly.	Install the paper tray correctly.
	The tray on the paper feeding path was not set correctly when the printer received the print job.	Install the paper tray correctly. The printer will restart printing automatically.
CLOSE FRONT COVER	The front cover is open.	Close the front cover. (⇒ P.1)
CLOSE LEFT COVER	The left cover is open.	Close the left cover. (⇒ P.1)
CLOSE PAPER EXIT COVER	The paper exit cover is open.	Close the paper exit cover. (⇒ P.3)

Message	Description	Comments
ERROR POWER OFF AND ON	There is a malfunction in the printer.	Turn the printer off and on. If this doesn't clear the problem, contact your sales or service representative.
FUSER OIL LOW	Fuser oil is low. You can print about 200 or / more pages after this message appears.	Replace the fuser oil bottle. ⇒ P.50 "Replacing the Fuser Oil Bottle and Ozone Filter"
LOAD PAPER IN (tray name)	There is no paper in the indicated tray.	Load paper into the indicated tray.
LOAD BYPASS (media type) (paper size)	There is no indicated media type and paper size in the bypass tray.	Load the indicated media or paper into the bypass tray.
LOAD (tray name) (paper size)	There is no indicated paper size in the paper tray.	Load the indicated paper into the paper tray.
OPEN FRONT COVER REMOVE MISFEED	There is a paper misfeed in the printer.	Remove the misfed paper. ⇒ P.38 "Removing Misfed Paper"
PAPER SIZE ERROR CHECK GUIDES ↓↑ OPEN AND CLOSE COVER TO CLEAR	There is a difference between the position of the paper guides in the bypass tray and the specified paper size set with the operation panel.	After confirming that the paper guides are set to the correct positions, open and close the front cover. ⇒ P.27 "Loading Paper in the Bypass Tray"
PAPER SIZE ERROR (paper size) ↓↑ OPEN AND CLOSE COVER TO CLEAR	There is a difference between the paper size in the paper tray and the specified paper size set with the operation panel or the paper size dial.	After confirming that the size and feed direction of paper in the paper tray is set correctly, open and close the front cover. ⇒ P.25 "Loading Paper in the Paper Tray"
REMOVE MISFEED FROM OUTPUT TRAY	There is a paper misfeed in the printer.	Remove the misfed paper. ⇒ P.38 "Removing Misfed Paper"
REMOVE MISFEED FROM INPUT TRAY	There is a paper misfeed in the printer.	Remove the misfed paper. ⇒ P.38 "Removing Misfed Paper"
REPLACE FUSING UNIT	The fusing unit is nearly at the end of its service life.	Contact your sales or service representative.

Message	Description	Comments
REPLACE PCU	The photoconductor unit is nearly at the end of its life.	If printed side gets dirty, replace the photoconductor unit. ⇒ P.48 <i>"Replacing the Photoconductor Unit"</i>
TONER LOW xxx	Indicated toner is low or runs out.	Replace the indicated toner cartridge. ⇒ P.45 <i>"Replacing the Toner Cartridge"</i>
WARMING UP	The printer is preparing for printing.	Wait until the printer is warmed up.
	The printer adjusts itself regularly to maintain print quality. (This message might appear while printing.)	It is not an error message. The printer is working properly. Just wait a while.
WASTE TONER ALMOST FULL	The waste toner bottle is nearly full.	Replace the waste toner bottle. ⇒ P.53 <i>"Replacing the Waste Toner Bottle and Charger"</i>
WASTE TONER FULL	The waste toner bottle is full.	Replace the waste toner bottle. ⇒ P.53 <i>"Replacing the Waste Toner Bottle and Charger"</i>

 **Note**

- ❑ If you cannot solve the problem by taking above actions, turn the printer power off and then back on again. If this doesn't clear the error message, write down the error number and the message, and contact your sales or service representative.

Printer Doesn't Print

4

Possible Cause	Solutions
Is the power on?	<p>Make sure that the power cord is securely plugged into the wall socket and the printer's power socket.</p> <p>Turn on the printer's power switch. ⇒ P.6 <i>"Turning the Printer On and Off"</i></p>
Is the interface cable properly connecting the printer to your computer connected securely?	<p>Connect the interface cable properly. If there are any connectors or screws, make sure they are fastened securely.</p> <p>See the "Quick Installation Guide" for details about the settings.</p>
Are you using a correct interface cable?	<p>The type of interface cable you should use depends on your computer. Be sure to use the correct one.</p> <p>If the cable is damaged or worn, replace it with a new one.</p> <p>See the "Quick Installation Guide" for details about the settings.</p>
Does the On Line indicator stay on?	<p>Press [On Line] to light it up.</p>
Is the paper set?	<p>Load paper into the paper tray or on the bypass tray. ⇒ P.25 <i>"Loading Paper"</i></p>
Does the Error indicator stay red?	<p>Check the error message on the panel display and do the required action. ⇒ P.29 <i>"Error & Status Messages on the Operation Panel"</i></p>

Possible Cause	Solutions
Is the Data In indicator blinking after starting the print job?	<p>If not, the data is not being sent to the printer. Or the printer may be resetting the print job because there was a long delay in receiving the data from the computer.</p> <ul style="list-style-type: none"> ❖ If your printer is connected to the computer using the interface cable Confirm that the parallel port setting is set to on. For more information on the printer port settings, see the "Getting Started". ❖ If the printer is using the I/O timeout setting Increase the value of the I/O timeout setting. For more information on the the I/O timeout setting, see the "Getting Started". ❖ Network Connection Contact your network administrator. <p>If the Data In indicator is blinking. Take the following steps to correct the situation.</p> <ul style="list-style-type: none"> • Wait until the printer finishes receiving data from the computer. • Cancel the job if the data sent from the computer is too large or complex.
Can you print a test page (configuration page)?	<p>If you cannot print a test page, it probably indicates a printer malfunction. You should contact your sales or service representative.</p> <p>If you can print a test page but cannot get the printer to print when you issue a print command from your computer, it probably means there is a problem with your computer.</p> <p>Also keep in mind that large, complex data might take long time for the printer process. For more information, see the "Getting Started".</p>

If you cannot solve the problem by taking the above actions, contact your sales or service representative.

 **Note**

- **Windows 95/98**

- ① Click **[Start]**, point to **[Settings]**, and then click **[Printers]**.
- ② Select the icon of the printer by clicking it. Next, on the **[File]** menu, click **[Properties]**.
- ③ Click **[Details]** tab.
- ④ Check the **[Print to the following port]** box to make sure the correct port is selected.

- **Windows NT4.0**

- ① Click **[Start]**, point to **[Settings]**, and then click **[Printers]**.
- ② Select the icon of the printer by clicking it. Next, on the **[File]** menu, click **[Properties]**.
- ③ Click **[Port]** tab.
- ④ Check the **[Print to the following port]** box to make sure the correct port is selected.

Other Printing Problems

Status	Possible Causes, Descriptions, and Solutions
Image is printed on the reverse side of the paper.	<p>The paper in the paper tray is upside down.</p> <ul style="list-style-type: none"> • Standard Tray (Tray 1) Load paper with the print side up. • Bypass Tray Load paper with the print side down. • Optional Paper Feed Unit (Tray 2, Tray 3) Load paper with the print side up.
Paper misfeeds occur frequently.	Check the paper size settings. The size specified with the paper size dial might be different from the actual paper size. Make the correct dial setting. ⇒ P.25 <i>“Loading Paper in the Paper Tray”</i>
	Check if the paper tray is set correctly. If not, set it correctly. ⇒ P.25 <i>“Loading Paper in the Paper Tray”</i>
	Paper is not loaded correctly in the paper tray. Remove the paper from the tray and reload it correctly. ⇒ P.25 <i>“Loading Paper in the Paper Tray”</i>
	Check the paper type settings. The type of paper set with the printer driver might be different from the actual paper or media type. Make the correct paper or media type setting.
	You might use paper not supported by this printer. Use the appropriate type of paper. ⇒ P.20 <i>“Precautions for Paper”</i>
Multiple pages are fed through the printer at once.	Clean the friction pad, if it is dirty. ⇒ P.42 <i>“Cleaning the Friction Pad”</i>
Operation panel error message stays on after removing the misfed paper.	After removing misfed paper, open the front cover of your printer and then close it. ⇒ P.38 <i>“Removing Misfed Paper”</i>
It takes too much time to print the first page.	The data is so large or complex that it takes time to process it. If the Data In indicator is blinking, the data processing is being done. Just wait until it resumes.
	The Energy Save mode might be enabled. In the Energy Save mode, it takes time for the machine to warm up.

Status	Possible Causes, Descriptions, and Solutions
It takes too much time to print.	Photographs and other data intensive pages take a long time for the printer to process, so simply wait when printing such data.
	The printer takes more time to print documents that contain a large volume of data. A blinking Data In indicator means that data is reaching the printer, so just wait for the data to be processed and printed.
	If "WARMING UP" appears on the panel display, the printer is now warming up. Wait for a while.
It takes too much time to perform black and white printing.	The color mode setting of the printer driver is set to color mode. Change the setting to grayscale mode. For more information, see the "User's Guide".
Paper isn't fed from the desired paper tray.	The printer driver setting is not correct. Change the setting. For more information, see the "User's Guide".
Desired paper size isn't used for the output.	The printer driver setting is not correct. Change the setting. For more information, see the "User's Guide".
	Check the paper size settings. The size specified with the paper size dial might be different from the actual paper size. Make the correct dial setting. ⇒ P.25 "Loading Paper in the Paper Tray"
	Specified paper is not loaded correctly in the paper tray. Remove the paper from the tray and reload the specified paper correctly. ⇒ P.25 "Loading Paper in the Paper Tray"
Printed side gets dirty.	The charger and dust-proofing glass are dirty. Clean the charger and dust-proofing glass. ⇒ P.42 "Cleaning the Charger" and P.43 "Cleaning the Dust-proofing glass"
	Check the image density setting. For more information, see the "Getting Started".
	If the message "REPLACE PCU" appears on the panel display, replace the photoconductor unit. ⇒ P.48 "Replacing the Photoconductor Unit"
Image density is too light.	Recalibrate the printer using the operation panel. For more information, see the "Getting Started".
	If the message "TONER LOW XXX" is on the panel display, replace the toner cartridge for the indicated color. ⇒ P.45 "Replacing the Toner Cartridge"
	You might be using paper not supported by this printer. Use the appropriate type of paper. ⇒ P.20 "Precautions for Paper"

Status	Possible Causes, Descriptions, and Solutions
Black or white lines appear on the print side.	The charger and dust-proofing glass are dirty. Clean the charger and dust-proofing glass. ⇒ P.42 <i>"Cleaning the Charger"</i> and P.43 <i>"Cleaning the Dust-proofing glass"</i>
Smearred toner appears on the printed side.	The charger is dirty. Clean the charger. ⇒ P.42 <i>"Cleaning the Charger"</i>
Part of the printout is blurred or light.	If the message "TONER LOW XXX" is on the panel display, replace the toner cartridge for the indicated color. ⇒ P.45 <i>"Replacing the Toner Cartridge"</i>
Toner is not fused well when printing on thick paper or OHP transparencies.	The printer is not in thick paper or OHP transparency mode. Select thick paper or OHP transparency mode using the printer driver. For more information, see the "User's Guide".
The color of the printout doesn't match the color on the computer's display.	The toner based color system used by the printer is different from the light based color system of the computer screen. For more information, see the "User's Guide".
	Recalibrate the printer using the operation panel. For more information, see the "Getting Started".
	Change the printer driver settings. For more information, see the "User's Guide".
Color documents are printed in black and white.	The printer driver is not set up for color printing. Change the setting to color printing. For more information, see the "User's Guide".
Thin lines are blurred or light.	Change the halftone settings of the printer driver. For more information, see the "User's Guide".
When printing on OHP transparencies, a sheet of paper is not placed between printed OHP transparencies.	There is no paper in tray 1. Load the same size and direction paper as the OHP transparency into tray 1.
	The "OHP SLIP SHEET" setting is set to "NO". Change the setting with operation panel. For more information, see the "Getting Started".

 **Note**

- If you cannot solve the problem by taking above actions, contact your sales or service representative.

Removing Misfed Paper

When a paper misfeed occurs, an error message appears on the panel display. The procedure you should follow to remove the misfed paper depends on its location which is indicated on the panel display.

⚠ CAUTION:

- *When removing misfed paper, do not touch the fusing section because it could be very hot.*
- *When accessing the inside of the machine, do not touch any sections other than those specified in this manual. If you do, it might result in receiving a burn or injury.*

4

⚠ Important

- ❑ If your printer is equipped with the optional tray, do not pull out more than one tray with paper at a time. If you do, the printer might tilt forward.
- ❑ Check the following points if paper continues to misfeed.
 - Make sure paper is properly loaded in the paper tray.
 - Make sure the number of sheets do not exceed the maximum capacity of the tray.
 - Make sure you are using only the appropriate type of paper.
 - Make sure misfed paper is still not inside the printer when you resume printing.
 - Check the paper type settings. The type of paper set with the printer driver might be different from the actual paper or media type. Make the correct paper or media type setting.

- ❑ Make sure the size of the paper loaded in tray 1 is same as the size of the OHP transparency.
- ❑ If misfeeds persist, contact your sales or service representative.
- ❑ Do not touch the photoconductor unit when removing misfed paper. If you do, the photoconductor unit might be damaged.
- ❑ Exposing the photoconductor unit to light for too long can reduce its performance. Close the cover as quickly as possible.
- ❑ After removing the misfed paper, the back sides of the next printout might get dirty. Print a few pages to absorb the toner.

When the Message "REMOVE MISFEED FROM INPUT TRAY" Appears

Standard Tray (Tray 1) or Paper Feed Unit (Tray 2/3)

- 1 Pull out the paper tray gently, being careful not to tear the misfed paper, and remove the misfed paper.

Make sure that you do not leave any misfed paper in the printer.

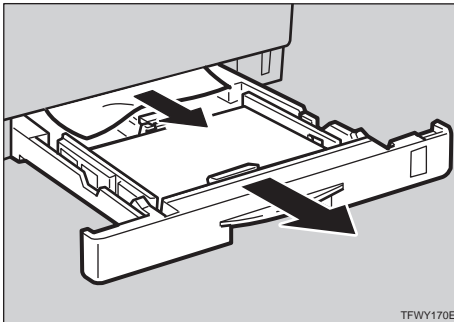

Note

- If your printer has an optional paper feed unit installed, check all paper trays for misfeeds.

- 2 Slide the paper tray completely into the printer.

Important

- Be sure to insert the paper tray completely. Otherwise, misfeeds might occur, or the front cover might touch the paper tray.

- 3 Open the front cover, and then close it to reset the misfeed condition.

Bypass tray

- 1 Carefully pull the misfed paper.

Make sure that you do not leave any misfed paper in the printer.

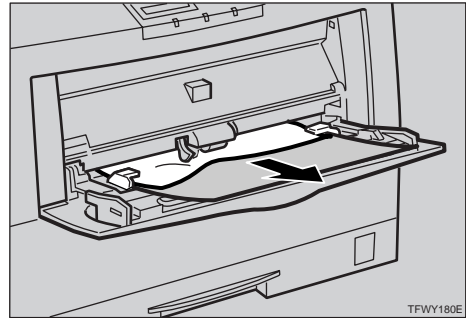

- 2 When paper is left in the bypass tray, remove the paper.

- 3 Close the bypass tray, open the front cover, and then close it to reset the misfeed condition.

- 4 Reload paper into the bypass tray.

When the Message "OPEN FRONT COVER REMOVE MISFEED" Appears

CAUTION:

- When removing misfed paper, do not touch the fusing section because it could be very hot.

- 1 Open the front cover by pushing the front cover release button.

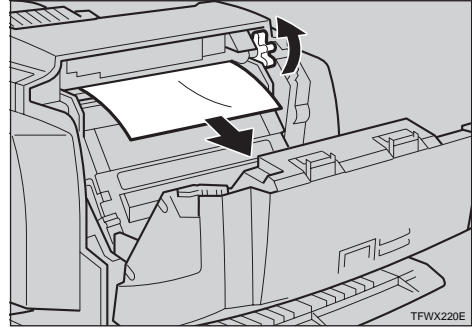
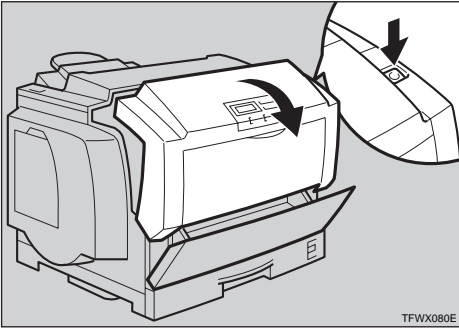

- 4 Close the front cover.

- 2 If the paper is in the front side of the photoconductor unit, carefully pull it out.

Note

- When removing misfed paper, be careful not to touch the fusing section because it could be very hot.

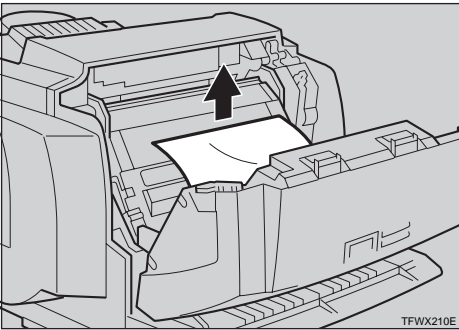

- 3 When the misfed paper is in the main section of the photoconductor unit, turn the dial downward then remove the misfed paper in the printer.

Make sure that you do not leave any misfed paper in the printer.

Note

- If it is difficult to turn the dial, turn it slightly upward in the opposite direction, and then try again.

When the Message "REMOVE MISFEED FROM OUTPUT TRAY" Appears

CAUTION:

- When removing misfed paper, do not touch the fusing section because it could be very hot.

- 1 Open the paper exit cover.

Note

- When opening the paper exit cover, be careful as it may be hot.

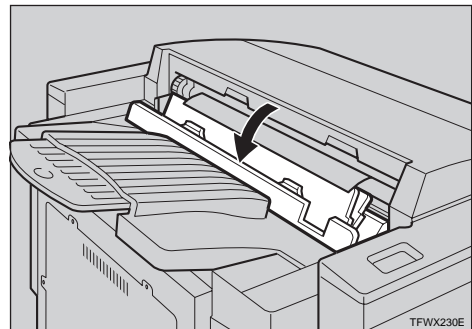

- 2** Open the front cover by pushing the front cover release button.

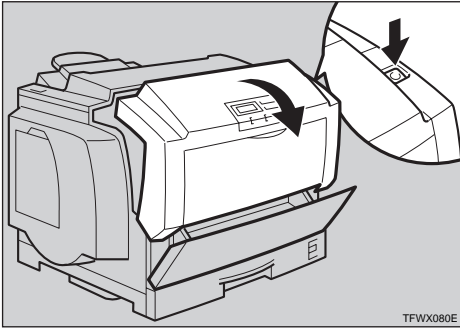

- 3** Turn the dial downward, then remove the misfed paper in the printer.

Note

- When removing misfed paper, be careful not to touch the fusing section because it could be very hot.

When you can see the misfed paper inside the printer.

Note

- If it is difficult to turn the dial, turn it slightly upward in the opposite direction, and then try again.

- 1** Remove the misfed paper from inside of the printer.

While turning the dial, remove the misfed paper as shown in the illustration. Be careful not to leave any misfed paper in the printer.

Note

- When removing misfed paper, be careful not to touch the fusing section because it could be very hot.

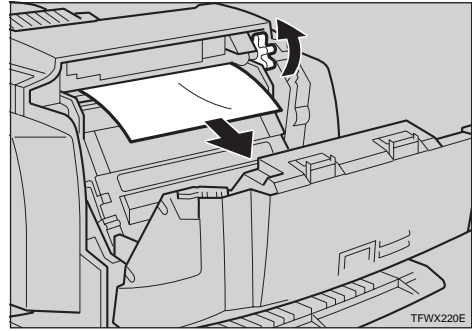

When you cannot see the misfed paper inside the printer.

- 1** Remove the misfed paper from the output tray.

While turning the dial, remove the misfed paper as shown in the illustration. Be careful not to leave any misfed paper in the printer.

Note

- When removing misfed paper, be careful not to touch the fusing section because it could be very hot.

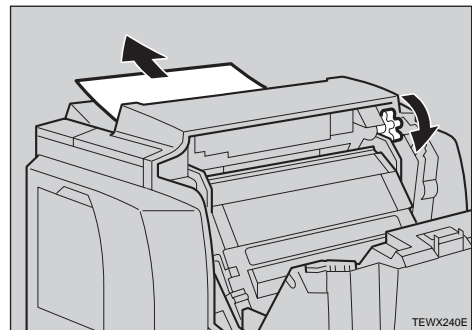

- 4** Close the paper exit cover.

- 5** Close the front cover.

Cleaning the Printer

Cleaning the Friction Pad

If the friction pad becomes dirty, mis-feeds or multi-feeds of paper might occur. In this case, clean the pad as follows:

- 1** Slide the paper tray out until it stops. After that, lift it slightly, then pull it out of the printer. Then remove the paper from the paper tray.
- 2** Clean the friction pad with a soft damp cloth. After wiping it with a damp cloth, wipe it with a dry cloth to remove the water.

Important

- Do not use chemical cleaners or organic solvents such as thinner or benzene.

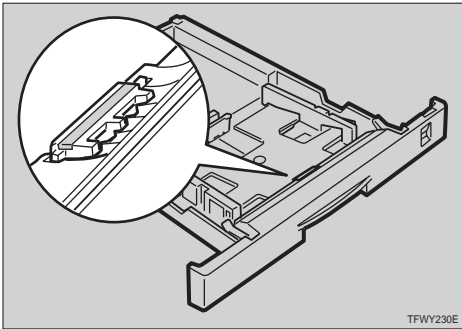

- 3** Load paper with the print side up into the paper tray. While lifting the front side of the tray, insert the paper tray into the printer. Then push in until it stops.

Cleaning the Charger

The charger requires cleaning when your printouts appear dirty.

CAUTION:

- When accessing the inside of the machine, do not touch any sections other than those specified in this manual. If you do, it might result in receiving a burn or injury.

- 1** Open the front cover by pushing the front cover release button.

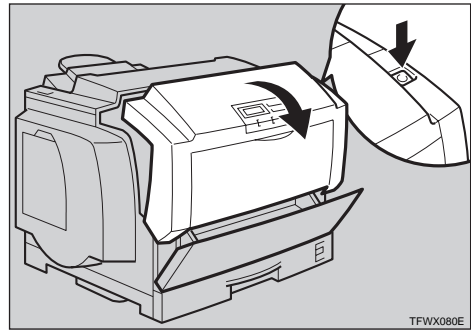

Important

- Exposing the photoconductor unit to light for too long can reduce its performance. Clean the charger as quickly as possible.

- 2** Hold the inset grips (green part) of the photoconductor unit, and pull the top side of the photoconductor unit forward.

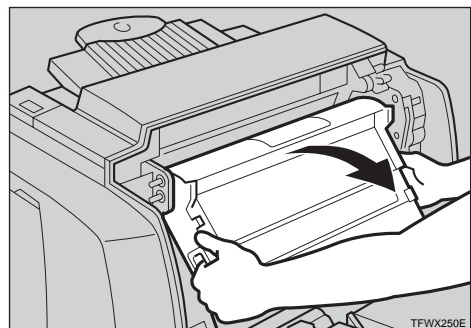

- 3** Move the charger cleaner (light blue part) left and right 2 or 3 times, and return it to the left side. Set the arrow of the charger cleaner to the arrow of the photoconductor unit.

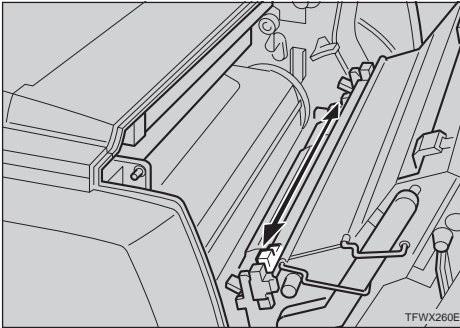

Important

- If the charger cleaner is not on the left side, an error message or print problem might occur.

- 4** Hold the inset grips (green part) of the photoconductor unit, and push the photoconductor unit to its original position.

- 5** Close the front cover.

Cleaning the Dust-proofing glass

The dust-proofing glass may require cleaning if black or white lines appear on the print side of the document.

CAUTION:

- When accessing the inside of the machine, do not touch any sections other than those specified in this manual. If you do, it might result in receiving a burn or injury.

- 1** Open the front cover by pushing the front cover release button.

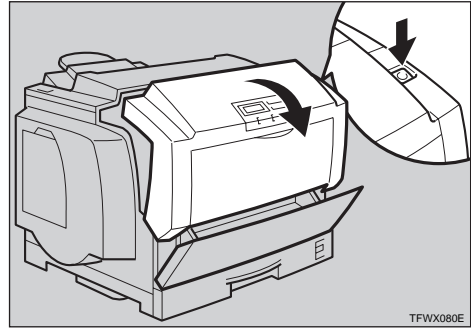

Important

- Exposing the photoconductor unit to light for too long can reduce its performance. Clean the dust-proofing glass as quickly as possible.

- 2** Hold the inset grips (green part) of the photoconductor unit, and pull the top side of the photoconductor unit forward.

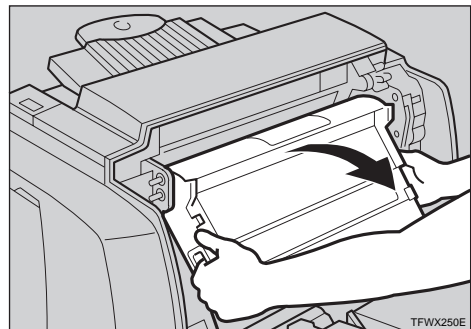

- 3** Remove the cleaning brush from back of the front cover.

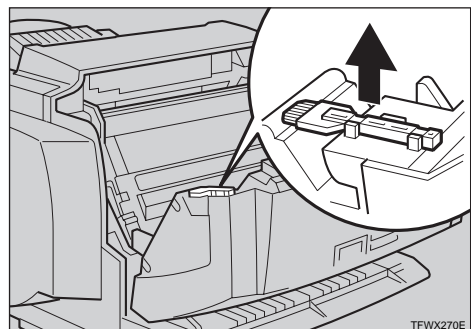

- 4** Insert the cleaning brush into the back of the guide (light blue) until it stops, and then move it left and right 4 or 5 times.

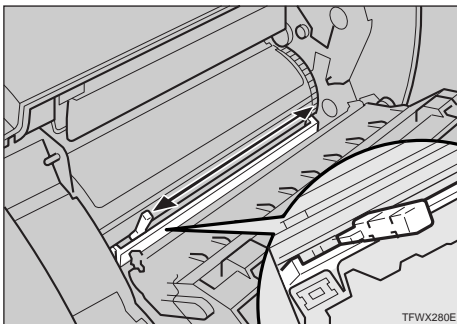

4

- 5** Return the cleaning brush to its original position.
- 6** Hold the inset grips (green part) of the photoconductor unit, and push the photoconductor unit to its original position.
- 7** Close the front cover.

Replacing Consumables

Replacing the Toner Cartridge

You should replace toner cartridges whenever the message "TONER LOW XXX" appears on the panel display.

TONER LOW
XXX

⚠ WARNING:

- **Do not incinerate spilled toner or used toner. Toner dust might ignite when exposed to an open flame.**
- **Disposal can take place at our authorized dealer or at appropriate collection sites.**
- **If you dispose of the used toner containers yourself, dispose of them according to your local regulations.**

📌 Note

- ❑ Before removing a toner cartridge from the printer, spread paper or some other material around the area you are working to keep toner from making floor dirty.
- ❑ When several toner colors run out at the same time, a message appears on the operation panel. Replace them in the following order:
 - ① Black
 - ② Yellow
 - ③ Cyan
 - ④ Magenta
- ❑ When there is no all color toner cartridges that you want to replace, you can specify the replacing toner cartridges. ⇒ P.47 "Specifying the replacing toner cartridge"

1 Open the left cover.

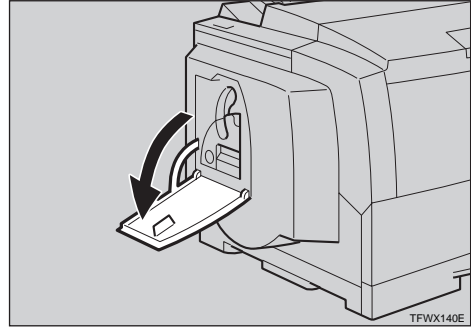

2 Slide the lock lever up.

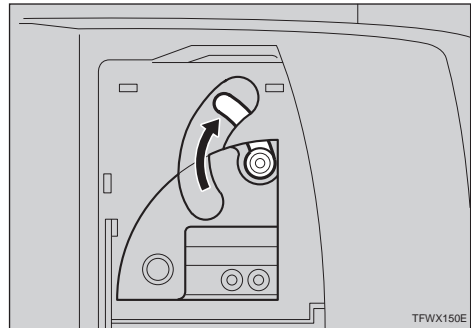

3 Carefully pull out the toner cartridge.

- ① Hold the grip of the toner cartridge, and slide it out until you can see the green tape.
- ② With your hand under the green tape, remove the toner cartridge carefully as shown in the illustration.

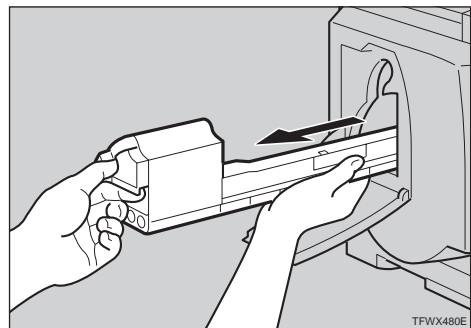

4 Remove the protective sheet from the new toner cartridge.

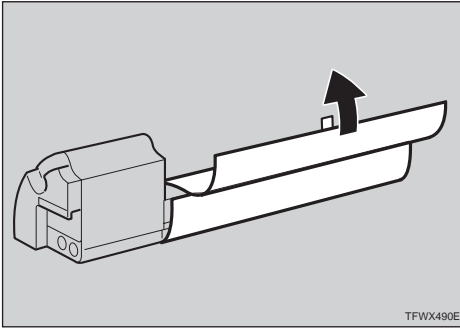

7 Return the lock lever to its original position.

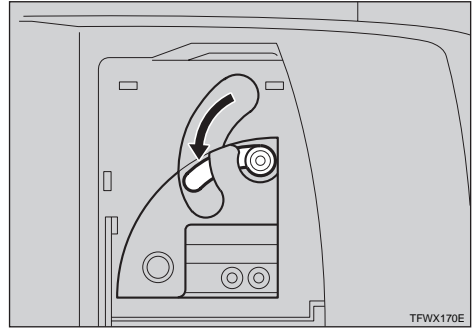

4

5 Hold the new toner cartridge and shake it with a horizontal motion, about 10 times, as shown in the illustration.

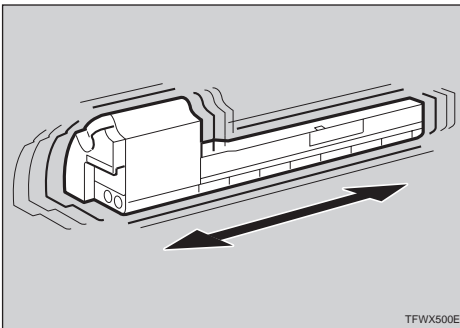

8 Pull the tape out as shown in the illustration.

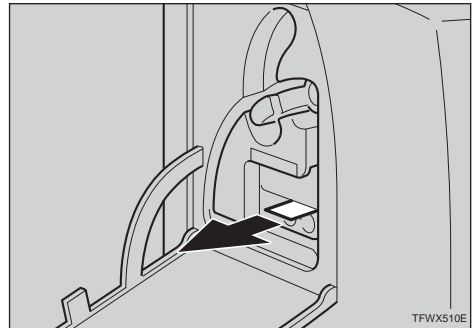

Important

- If the toner cartridge is not shaken enough, toner might not be evenly distributed in the cartridge. In this case, the print quality might be reduced.

Important

- Be sure to pull the tape horizontally. Pulling it upward or downward causes toner scattering.
- After pulling the tape out of the cartridge, toner scatters easily. Do not shake or give a shock to the cartridge.

6 Slide the new toner cartridge into the printer.

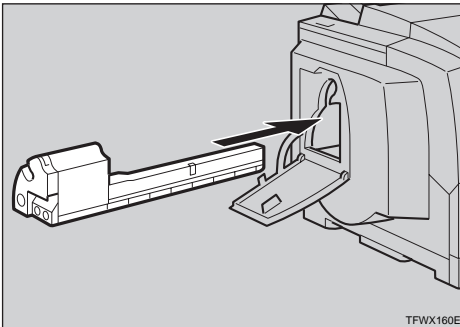

9 Close the left cover.

The "TONER LOW XXX" message clears from the panel display and the printer starts warming up. It takes a few minutes.

Specifying the replacing toner cartridge

When several toner colors run out at the same time, you can replace only the specific toner cartridges. If you do not have all indicated toners, you should do this before following P.45 "Replacing the Toner Cartridge".

The following procedure describes how to replace the magenta toner cartridge. You can use the same procedure to replace the toner cartridges for the other toner colors as well.

- 1 Press **[Menu]**.

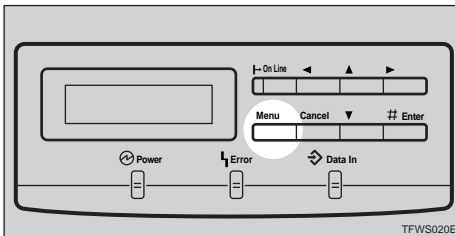

- 2 Use **[▲][▼]** to display "MAINTENANCE", and then press **[Enter]**.

```
MAINTENANCE
```

The following message appears on the panel display.

```
SELECT TONER
NO *
```

- 3 Use **[▲][▼]** to select "YES", and then press **[Enter]**.

The following message appears on the panel display.

```
CYAN TONER
NO *
```

- 4 Press **[Enter]** to display "MAGENTA TONER".

The following message appears on the panel display.

```
MAGENTA TONER
NO *
```

- 5 Use **[▲][▼]** to select "YES", and then press **[Enter]**.

The following message appears on the panel display.

```
MAGENTA TONER
PLEASE WAIT
```

The machine prepares itself for a new toner cartridge. Prepare the new toner cartridge for installation.

When the machine is ready, the following message is displayed.

```
REPLACE TONER
MAGENTA
```

- 6 Replace the toner cartridge. ⇒ P.45 "Replacing the Toner Cartridge"

Replacing the Photoconductor Unit

The message shown below indicates that the photoconductor unit is approaching the end of its life.

REPLACE PCU

You can still continue to use the current photoconductor unit if you are satisfied with the quality of the output being produced by the printer.

When the printed image starts looking soiled (horizontal lines along the edges of the page, for example), replace the photoconductor unit as soon as possible.

⚠ WARNING:

- ***Do not incinerate the photoconductor unit. Toner dust might ignite when exposed to an open flame.***
- ***Disposal can take place at our authorized dealer or at appropriate collection sites.***
- ***If you dispose the used photoconductor unit yourself, dispose of it according to your local regulations.***

⚠ CAUTION:

- ***When accessing the inside of the machine, do not touch any sections other than those specified in this manual. If you do, it might result in receiving a burn or injury.***

⚡ Important

- ❑ Exposing the photoconductor unit to light for too long can reduce its

performance. Replace the unit as quickly as possible.

✎ Note

- ❑ Before removing the photoconductor unit from the printer, spread paper or some other material around the area you are working to keep toner from making floor dirty.
- ❑ The “REPLACE PCU” message is based on a printed page counter kept internally by the printer. It is meant as a general guide to photoconductor unit life only. Actual photoconductor unit life depends on the printing conditions.

1 Remove the new photoconductor unit from the box.

2 Remove the protective sheet by pulling the red tab from the new photoconductor unit.

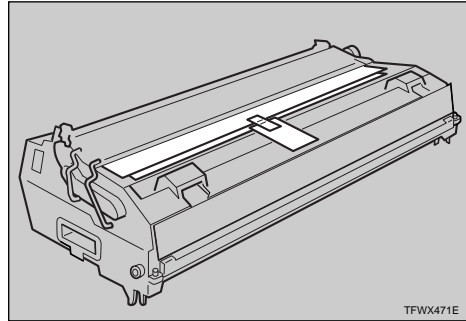

3 Turn off the printer's power switch.

- 4** Open the front cover by pushing the front cover release button.

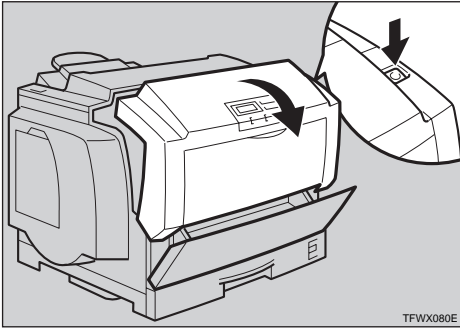

- 5** Loosen the screws that hold the photoconductor unit in the printer with the screw driver in the new photoconductor unit's box.

The screws cannot be completely removed from the photoconductor unit.

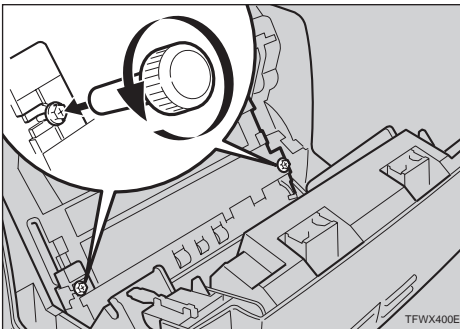

- 6** Hold the inset grips (green part) of the photoconductor unit, and pull the top side of the photoconductor unit forward.

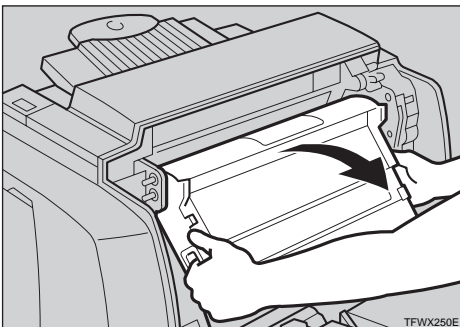

- 7** Hold the inset grips (green part) of the photoconductor unit, remove the photoconductor unit from the printer, and place it carefully inside the new photoconductor unit's box.

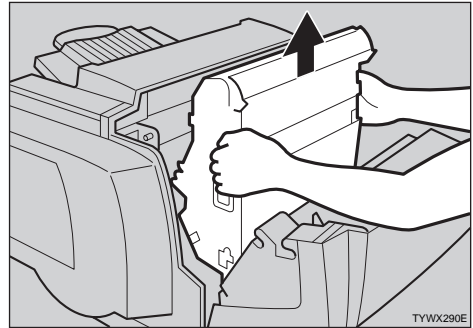

Important

- To prevent accidental spilling of toner, do not shake, rotate, drop or hold the toner cartridge upside down.

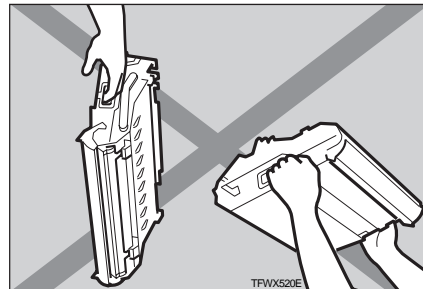

Note

- ❑ Do not close the front cover removing the photoconductor unit. Otherwise, you cannot replace the photoconductor unit because the photoconductor unit holder will be closed. If you do this by mistake, return the photoconductor unit holder to its original position before replacing the photoconductor unit.

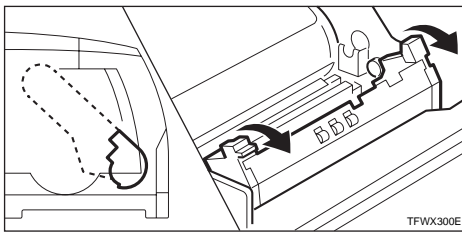

- 8** Hold the inset grips (green part) of the new photoconductor unit, and insert the photoconductor unit into the photoconductor unit holder.

When inserting the photoconductor unit, be careful not to damage the surface of it.

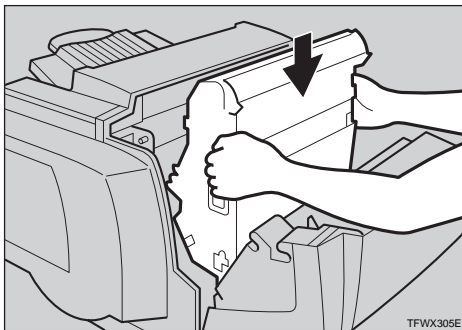

Note

- ❑ The white powder on the photoconductor unit is to protect it after installation into the printer. This white powder doesn't have any adverse effect on the interior of the printer.

- 9** Hold the inset grips (green part) of the new photoconductor unit, and push the photoconductor unit to its original position.

- 10** Fix the photoconductor unit with fastening the screws using the screw driver.

- 11** Close the front cover.

Make sure that the front cover close properly.

- 12** Turn on the printer's power switch.

Replacing the Fuser Oil Bottle and Ozone Filter

Replace the oil bottle and ozone filter whenever the message shown below appears on the panel display.



There is the fuser oil bottle and the ozone filter in the Fuser Oil Type305.

⚠ WARNING:

- **Do not incinerate the oil bottle. This action could cause a fire or getting burned.**
- **Spilt oil is very slippery. If oil is spilt, wipe it with alkaline cleaner. Otherwise, the oily surfaces can create the danger of slipping and personal injury.**

⚠ CAUTION:

- When accessing the inside of the machine, do not touch any sections other than those specified in this manual. If you do, it might result in receiving a burn or injury.

⚠ Important

- ❑ There are three ozone filters in this printer. Two of them are set inside in the front, one of them is set in the rear. Be careful when replacing the ozone filters as the front side filter is a different shape from the rear side filter.
- ❑ Disposal can take place at our authorized dealer or at appropriate collection sites.
- ❑ Dispose of used ozone filters as general burnable refuse.

1 Turn off the printer's power switch.

2 Replace the oil bottle.

1 Remove the green cap from the new oil bottle.

⚠ Important

- ❑ Hold the clear cap while turning the green cap. Do not remove the clear cap.

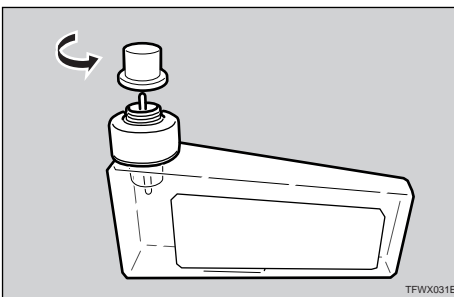

2 Open the fuser oil bottle cover of the printer.

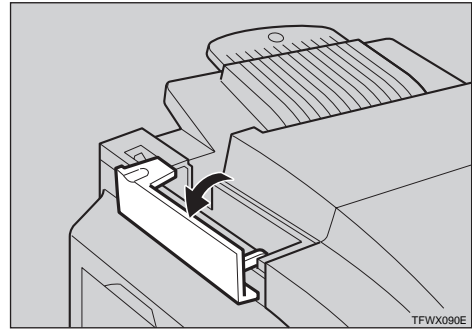

3 Remove the used oil bottle from the printer carefully.

4 Insert the new oil bottle into the oil bottle case.

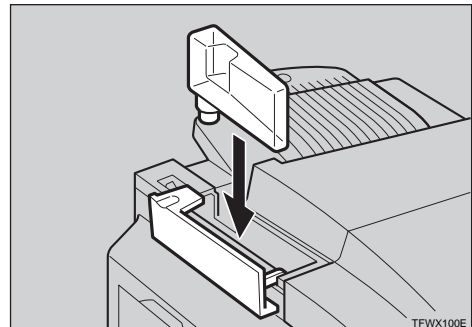

5 Close the fuser oil bottle cover.

⚠ Important

- ❑ The fuser oil bottle cover should be kept closed.

3 Replace the ozone filter on the back side of the printer.

1 Remove the ventilator hole cover.

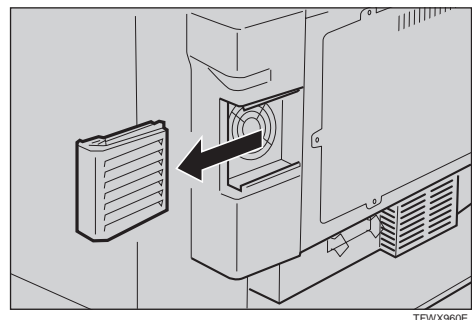

- 2** Remove the ozone filter from inside the ventilator hole cover.

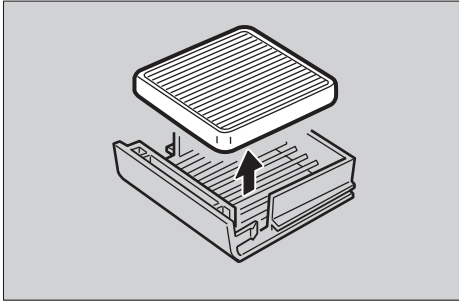

- 3** Install a new ozone filter on the ventilator hole cover.

- 4** Replace the ventilator hole cover onto the printer.

- 4** Replace the ozone filters inside the printer. (There are two filters.)

- 1** Open the front cover by pushing the front cover release button.

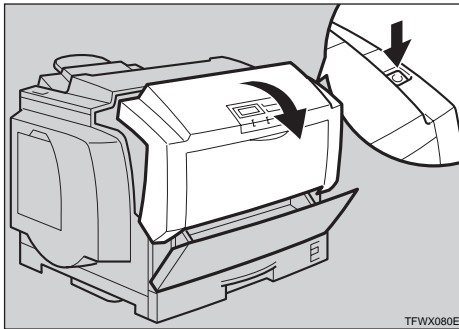

- 2** Grasping the ozone filter by its tab, remove it from the printer.

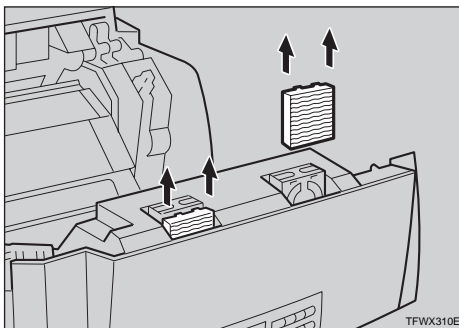

- 3** Insert a new ozone filter into the printer.

Slide the filter into the stopper. Two small thin plastic tabs of the top of the filter should pop into place.

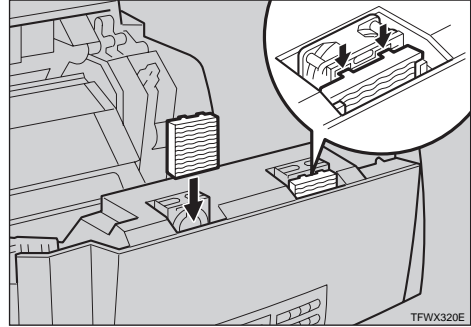

- 4** Close the front cover.

Make sure that the front cover close properly.

- 5** Turn on the printer's power switch.

Note

- After replace the fuser oil bottle, it takes a few minutes until the message clears.

Replacing the Waste Toner Bottle and Charger

You should replace waste toner bottle and charger whenever the following messages appear on the panel display.

WASTE TONER
ALMOST FULL

WASTE TONER
FULL

⚠ **WARNING:**

- *Do not incinerate spilled toner or used toner. Toner dust might ignite when exposed to an open flame.*
- *Disposal can take place at our authorized dealer or at appropriate collection sites.*
- *If you dispose of the used toner containers yourself, dispose of them according to your local regulations.*

⚠ **CAUTION:**

- *When accessing the inside of the machine, do not touch any sections other than those specified in this manual. If you do, it might result in receiving a burn or injury.*

🔧 **Note**

- ❑ Before removing the waste toner bottle from the printer, spread paper or some other material around the area you are working to keep toner from making floor dirty.

1 Turn on the printer's power switch.

2 Open the front cover by pushing the front cover release button.

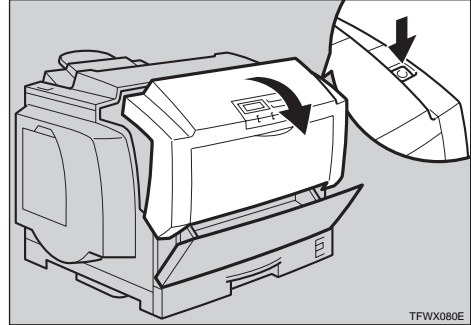

3 Hold the inset grips (green part) of the photoconductor unit, and pull the top side of the photoconductor unit forward.

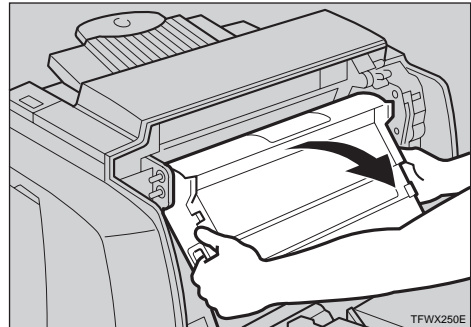

4 Replace the waste toner bottle .

1 Grasping the waste toner bottle by its green tabs, remove it from the printer.

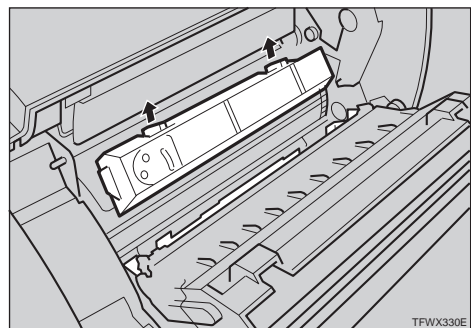

2 Insert a new waste toner bottle at the rear of the photoconductor unit.

Insert a new waste toner bottle completely. Otherwise, print problem may occur.

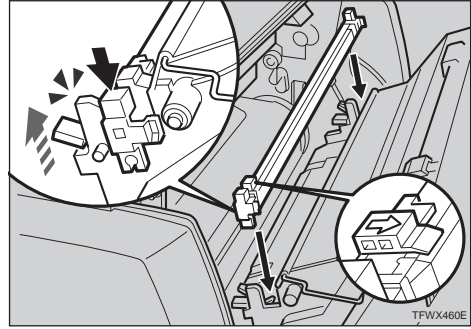
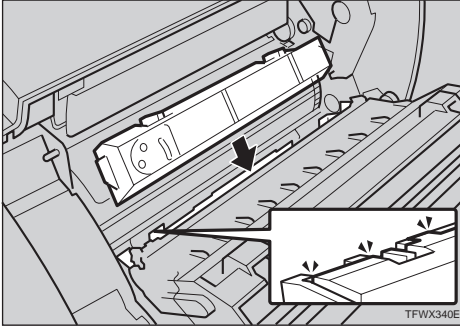

Note

- Return the charger cleaner to the left side. Otherwise, print problem may occur.

5 Replace the charger.

1 Push the right and left lock levers of the charger.

The locks release, and the charger is lifted slightly.

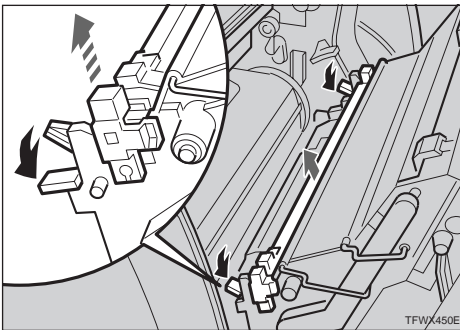

2 Remove the charger.

3 Install a new charger into the printer.

Insert the new charger into the printer with the arrow of the charger cleaner's lever facing toward you. The charger locks automatically.

6 Hold the inset grips (green part) of the new photoconductor unit, and push the photoconductor unit to its original position.

7 Close the front cover.

Make sure that the front cover close properly.

8 Turn on the printer's power switch.

Moving and Transporting the Printer

CAUTION:

- *It is recommended that at least two persons are used to lift the machine. Otherwise, the machine might fall and cause personal injury.*
- *When lifting the machine, use the inset grips on both sides of the machine. Otherwise, the machine might fall and cause personal injury.*
- *When you move the machine, unplug the power cord from the wall socket to avoid a fire or an electric shock.*
- *When you pull out the plug from the socket, grip the plug to avoid damaging the cord and causing a fire or an electric shock.*
- *When moving the printer, be sure to keep it level to avoid spilling the fuser oil. If oil is spilt, wipe it with alkaline cleaner. Otherwise, the oily surfaces can create the danger of slipping and personal injury.*

Important

- Be sure to disconnect all cables from the printer before transporting it.
- The printer is a precision piece of machinery. Take care to avoid damage during shipment.

Specifications

Mainframe

❖ Configuration:

Desktop

❖ Print Process:

Laser beam and dry toner electrical photographic system

❖ Printing Speed:

Monochrome: 17 pages per minute (A4, 8¹/₂"×11")

Color: 5 pages per minute (A4, 8¹/₂"×11")

❖ Resolution:

600 dpi

❖ Parallel Interface:

Conforms to the standard centronics

Interface

A standard 36-pin printer cable and a parallel port on the host computer

Mode

Compatible, Nibble, ECP

Connector

IEEE P1284-B

- Do not use a cable more than 2.5 meters (8.2 feet) long.

❖ Printer Language:

Adobe PostScript Level3, PCL5c/5e

❖ Paper Size:

⇒ P.15 *"Paper and Other Media Supported by this Printer"*

❖ Paper Weight:

⇒ P.15 *"Paper and Other Media Supported by this Printer"*

❖ Power Source:

⇒ Inside of the front cover of this manual

❖ Power Consumption:

Standby (Maximum)	150 W or less
Printing (Maximum)	1,200 W or less
Printing (Average)	750 W or less
Energy Save (Maximum)	45 W or less

❖ **Noise Emission (Sound Power Level):**

Printing	Less than 64 db(A)
Stand-by	Less than 43 db(A)

✎ **Note**

☐ The above measurements are made in accordance with ISO7779.

❖ **Dimensions:**

	Width	Depth	Height
Printer only	660 mm (26")	625 mm (24.7")	475 mm (18.8")
With one optional paper feed unit	660 mm (26")	625 mm (24.7")	601 mm (23.7")
With two optional paper feed units	660 mm (26")	625 mm (24.7")	727 mm (28.7")

Measurement conditions: With paper tray, bypass tray and output tray extender closed.

❖ **Weight:**

Approximately 62 kg (136.7 lb) (including consumables)

❖ **Warm-up Time:**

Less than 450 seconds (23°C)

❖ **Paper Capacity:**

Standard paper tray	250 sheets * ¹
Bypass tray	50 sheets * ¹
Optional paper feed unit	500 or 1,000 sheets * ¹

*¹ Paper weight: 80 g/m², 20 lb

❖ **Paper Output Capacity:**

A4: 250 sheets (80 g/m², 20 lb)

A3: 100 sheets (80 g/m², 20 lb)

❖ **CPU:**

R4700-133MHz

❖ **Memory:**

Standard 32MB, Up to 160MB (with optional memory unit)

❖ **Network:**

Topology: Ethernet (10BASE-T/100BASE-TX, 10BASE5), TokenRing (Option)

Protocol: TCP/IP, IPX/SPX, AppleTalk, SMB

❖ **Optional Equipment:**

- Paper Feed Unit Type305
- Memory Unit Type505 (32MB/64MB) (DIMM)
- Printer Hard Disk Type505

Options

Paper Feed Unit Type305

- ❖ **Paper Size:**
⇒ P.15 *"Paper Types and Sizes"*
- ❖ **Paper Weight:**
⇒ P.15 *"Paper Types and Sizes"*

Memory Unit Type505 (32MB) and Memory Unit Type505 (64MB)

- ❖ **Model Type:**
DIMM (Dual In-Line Memory Module)
- ❖ **Memory Type:**
PC100 SDRAM (precisely described as PC100 Rev1.0 compatible)
- ❖ **Number of Pins:**
168 pins
- ❖ **Access Time (Frequency):**
100MHz
- ❖ **CAS Latency:**
2

Printer Hard Disk Type505

- ❖ **Type:**
2.5 inch slim type (8.45mm height)
- ❖ **Storage Capacity (Formatted):**
1.62GB
- ❖ **Disk Rotational Speed:**
4,200rpm
- ❖ **Seek Time (Average):**
13ms
- ❖ **Host Interface:**
EIDE (UDMA mode supported)

Consumables

CAUTION:

- *Our products are engineered to meet the highest standards of quality and functionality. When purchasing expendable supplies, we recommend using only those specified by an authorized dealer.*

❖ Toner Cartridge

	Average printable number of pages per cartridge *1
COLOR TONER Type305 Cyan	15,000 pages
COLOR TONER Type305 Magenta	15,000 pages
COLOR TONER Type305 Yellow	15,000 pages
TONER Type305 Black	15,000 pages

*1 A4 5% test chart

Note

- The actual number of printed pages you get from a particular toner cartridge depends on the type and size of paper you are using, the contents of your print images, and printing environment conditions. The life of a toner cartridge also shortens as the cartridge becomes older. All this means that a toner cartridge might require replacement sooner than the normal life described above.
- Toner cartridges that come with the printer are for setup purposes, and will not provide the number of pages described above. The average number of printable pages that can be expected from the toner cartridges included in the printer are as follows:
 - Black toner cartridge : about 6,000 pages
 - Cyan, magenta and yellow toner cartridges : about 3,000 pages for each

❖ Other Consumables

Note

- ❑ Actual life of consumables depends on the type and size of paper you are using, the contents of your print images, and printing environment conditions. The life of consumables also shortens as the consumables become older. All that means that consumables might require replacement sooner than the life indicated.

	Service Life ^{*1}
Waste Toner Bottle Type305 ^{*4}	20,000 pages ^{*2}
	5,000 pages ^{*3}
Photo Conductor Unit Type305	60,000 pages ^{*2}
	15,000 pages ^{*3}
Fuser Oil Type305	20,000 pages

^{*1} A4 5% test chart

^{*2} For monochrome printing

^{*3} For full color printing

^{*4} Waste Toner Bottle Type305 includes a charger.

INDEX

A

Adhesive labels, 21

B

Back Plate, 3
Bypass Tray, 2, 27

C

[Cancel] key, 5
Charger, 4, 42, 53

D

Data In indicator, 5
Dust-proofing glass, 43

E

[Enter] key, 5
Error indicator, 5
Error & Status Messages on the Operation Panel, 29

F

Friction Pad, 42
Front Cover, 1
Front Cover Release Button, 1
Fuser Oil Bottle, 4, 50
Fuser Oil Bottle Cover, 1

I

Inset Grips, 1

L

Left Cover, 1

M

Memory Unit Type505, 8, 9
[Menu] key, 5
Misfed Paper, 38

N

Network Interface Connector for 10BASE5, 3
Network Interface Connector for 10BASE-T/100BASE-TX, 3

O

OHP transparency, 22
On Line indicator, 5
[On Line] key, 5
Operation Panel, 1
Options, 7
Output Tray, 1
Output Tray Extender, 1, 28
Ozone Filter, 3, 4, 50

P

Panel Display, 5
Paper, 15, 25
Paper Exit Cover, 3
Paper Feed Unit Type305, 8, 13
Paper Tray, 2, 25
Parallel Interface Connector, 3
Photoconductor Unit, 4, 48
Plain paper, 20
Power Connector, 3
Power indicator, 5
Power Switch, 1
Printable Area, 24
Printer Hard Disk Type505, 8, 11

T

Thick Paper, 21
Toner Cartridge, 4, 45

V

Ventilator, 3

W

Waste Toner Bottle, 4, 53